

Electric Actuators with Process Controllers

TROVIS 5724-8 (without fail-safe action)

TROVIS 5725-8 (with fail-safe action)



For heating and cooling applications

Application

Electric actuators with integrated PID control modules for simple industrial applications as well as heating, ventilation and air-conditioning systems. For globe and three-way valves, e.g. Types 3222, 3213, 3214, 2488, 42-36 E, 3226 and 3260 as well as Series V2001 in nominal sizes DN 15 to 50.



The TROVIS 5724-8 and TROVIS 5725-8 Electric Actuators with Process Controllers are a combination of an electric actuator and an integrated digital controller with two PID control modules.

The TROVIS 5724-8 Actuator is without fail-safe action and TROVIS 5725-8 with fail-safe action. The TROVIS 5724-8 has a manual override to manually move the valve in de-energized state.

Special features

- Universal unit with integrated process controller for
 - Flow temperature control based on the outdoor temperature (heating)
 - Differential temperature control in district cooling plants
- The TROVIS 5724-8xx and TROVIS 5725-8xx are available in four ready-wired device versions including sensors and control line to facilitate installation
- Fast start-up using configured systems for fixed set point, follow-up, override, cascade or switchover control
- Operating panel with display for set point adjustment and adjustable operating functions, e.g. start/stop control sequence
- Set point range from -50 to $+150$ °C, adjustment range can be limited
- Maximum power consumption 5 VA (< 44 kWh p.a.), degree of protection IP 54 according to IEC 60529
- Pump output to control a circulation pump can alternatively be used as a fault alarm output (connected wire L')
- Configuration, parameterization, diagnostic function and direct connection for monitoring using the TROVIS-VIEW software over Bluetooth®

Typetested version

The TROVIS 5725-8 Electric Actuator with Process Controller is tested in the force-locking version together with various SAMSON valves by the German Technical Inspectorate (TÜV) according to DIN EN 14597. The registration number is available on request.

Note: Details on Types 3222, 3213, 3214, 2488, 42-36 E, 3226 and 3260 as well as Series V2001 Valves can be found

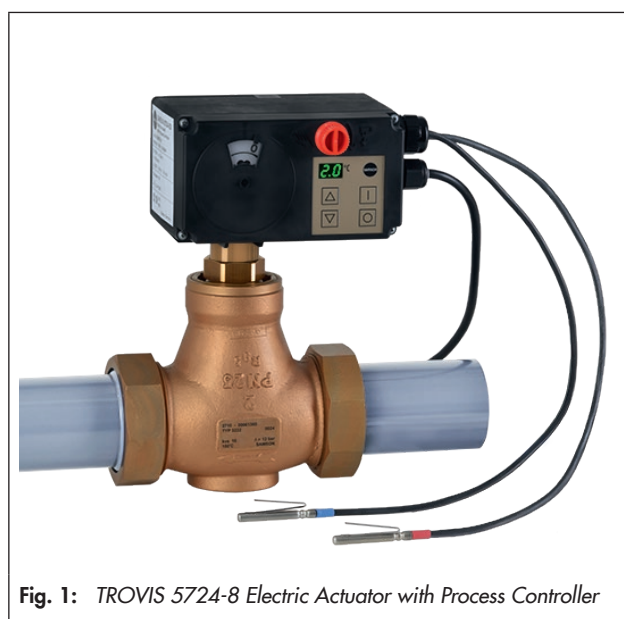

Fig. 1: TROVIS 5724-8 Electric Actuator with Process Controller

in Information Sheet ► T 5800 EN and in the associated data sheets.

Accessories for communication

- TROVIS-VIEW software
The TROVIS-VIEW software can be downloaded free of charge from our website (► www.samson.de at Services > Software > TROVIS-VIEW). The software can also be supplied on a CD-ROM. Further details in Data Sheet ► T 6661 EN.

Accessories for control

- Single-channel digital time switch with weekly program, Theben TR610 top2 G, order no. 1402-1017

Accessories for sensors

- Mounting kit for a Pt 1000 cable sensor (contact sensor), order no. 8524-0020
- Brass thermowell, G 1/2, immersion length 80 mm, PN 16, order no. 1099-0807
- CrNiMo steel thermowell, G 1/2, immersion length 80 mm, PN 40, order no. 1099-0805

- CrNiMo steel thermowell, G ½, immersion length 250 mm, PN 40, order no. 1099-0806
- Brass thermowell, G ½, immersion length 160 mm, PN 16, order no. 8525-5005
- CrNiMo steel thermowell, G ½, immersion length 160 mm, PN 40, order no. 8525-5011

Principle of operation

The electric actuators with process controllers can be used for diverse control tasks in heating and cooling applications. The actuators are available in four different versions which are adapted to the various tasks. See Table 1.

Ready-configured systems are available to facilitate start-up. As a result, the user only needs to change very few settings to adapt the device to the application. The user selects the system code number and changes parameter settings in the TROVIS-VIEW software.

TROVIS 5724-8 without fail-safe action

The actuator contains a reversible synchronous motor and a maintenance-free gear. The force of the motor is transmitted to the actuator stem via gearing and cam disk. When the actuator stem extends, it pushes against the valve's plug stem.

When the actuator stem retracts, the return spring in the valve causes the plug stem to follow the movement (force-locking connection). The valve and actuator have a force-locking connection. A form-fit connection is used for special valve models, e.g. Series V2001 valves.

The user can read and change the set point and operating values at the control panel. All other parameters can be changed in the TROVIS-VIEW software. Bluetooth® is used for data exchange between the actuator and computer.

After a power supply failure, the electric actuator starts again with a zero calibration and the last valid setting.

TROVIS 5725-8 with fail-safe action

The electric actuators with fail-safe action largely corresponds to the TROVIS 5824-8 described above. However, they also include a spring mechanism and an electromagnet.

Installation

Before mounting the actuator on the valve, retract the actuator stem.

Mounting position

The actuator can be mounted in any desired position. However, a suspended mounting position is not permissible.

Ordering text

Electric actuator with process controller
TROVIS 5724-8xx without fail-safe action/
TROVIS 5725-8xx with fail-safe action
Thrust ... N
Rated travel ... mm
Power supply 230 V, 50 Hz

Table 1: Available device versions

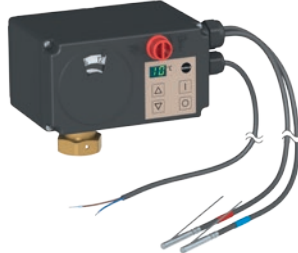
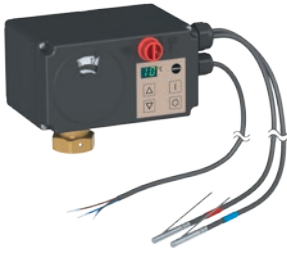
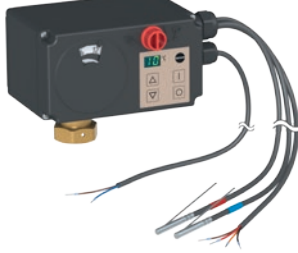
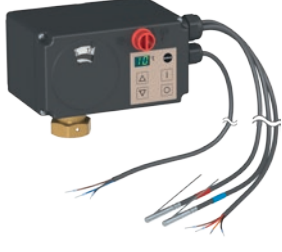
Device version [A]		<ul style="list-style-type: none"> - Two-wire connecting lead with open end for connection to power supply (5 m) - Two Pt 1000 sensors (3 m red and 2 m blue)
Device version [B]		<ul style="list-style-type: none"> - Three-wire connecting lead with open end for connection to power supply and switching output (2.5 m) - Two Pt 1000 sensors (3 m red and 2 m blue)
Device version [C]		<ul style="list-style-type: none"> - Two-wire connecting lead with open end for connection to power supply (5 m) - Two Pt 1000 sensors (3 m red and 2 m blue) - Four-wire control line for two additional inputs (3 m)
Device version [D]		<ul style="list-style-type: none"> - Three-wire connecting lead with open end for connection to power supply and switching output (2.5 m) - Two Pt 1000 sensors (3 m red and 2 m blue) - Four-wire control line for two additional inputs (3 m)

System code numbers

The system code numbers allow the user to use preconfigurations of the electric actuators with process controllers in TROVIS-VIEW for a certain application.

System code numbers for heating applications

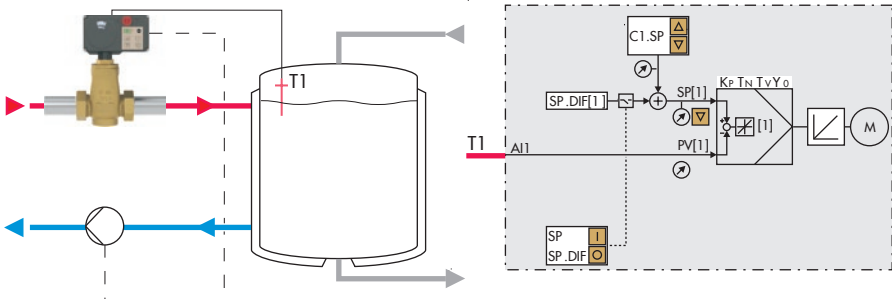
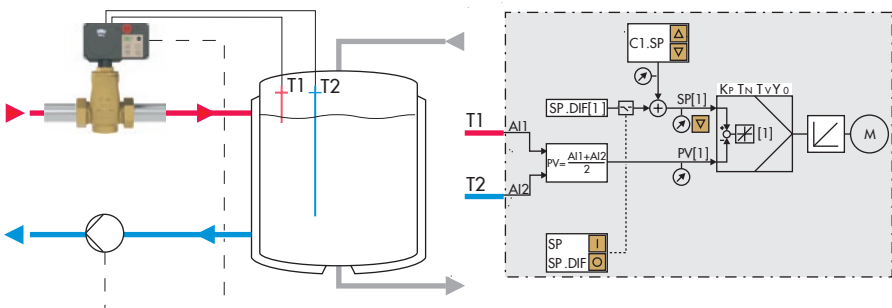
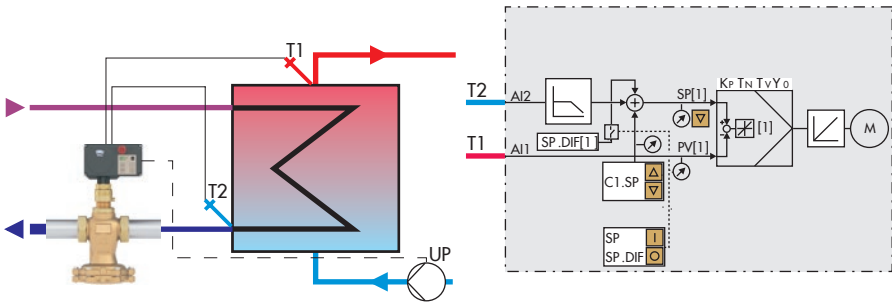
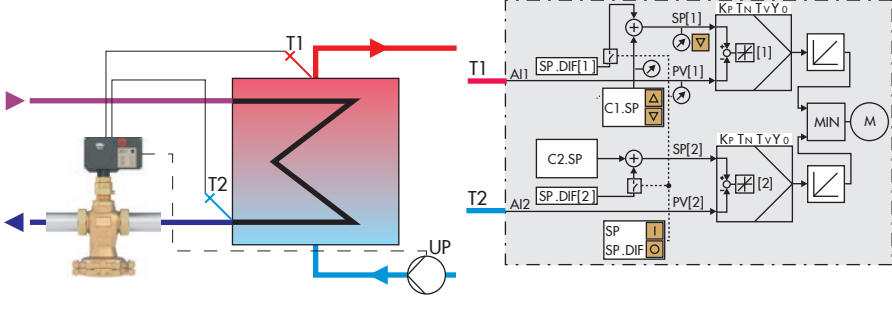
<p>System code number 1</p> <ul style="list-style-type: none"> Fixed set point control with one sensor <p>Device version:</p> <table border="1"> <thead> <tr> <th>[A]</th> <th>[B]</th> <th>[C]</th> <th>[D]</th> </tr> </thead> <tbody> <tr> <td>○</td> <td>●</td> <td>○</td> <td>●</td> </tr> </tbody> </table>	[A]	[B]	[C]	[D]	○	●	○	●	
[A]	[B]	[C]	[D]						
○	●	○	●						
<p>System code number 10 (default setting)</p> <ul style="list-style-type: none"> Fixed set point control Mean value calculation using two sensors Switching output e.g. for pump control <p>Device version:</p> <table border="1"> <thead> <tr> <th>[A]</th> <th>[B]</th> <th>[C]</th> <th>[D]</th> </tr> </thead> <tbody> <tr> <td>○</td> <td>●</td> <td>○</td> <td>●</td> </tr> </tbody> </table>	[A]	[B]	[C]	[D]	○	●	○	●	
[A]	[B]	[C]	[D]						
○	●	○	●						
<p>System code number 30</p> <ul style="list-style-type: none"> Fixed set point/follow-up control Return flow temperature limitation Switching output e.g. for pump control <p>Device version:</p> <table border="1"> <thead> <tr> <th>[A]</th> <th>[B]</th> <th>[C]</th> <th>[D]</th> </tr> </thead> <tbody> <tr> <td>○</td> <td>●</td> <td>○</td> <td>●</td> </tr> </tbody> </table>	[A]	[B]	[C]	[D]	○	●	○	●	
[A]	[B]	[C]	[D]						
○	●	○	●						
<p>System code number 50</p> <ul style="list-style-type: none"> Override control with minimum selection Return flow temperature limitation Switching output e.g. for pump control <p>Device version:</p> <table border="1"> <thead> <tr> <th>[A]</th> <th>[B]</th> <th>[C]</th> <th>[D]</th> </tr> </thead> <tbody> <tr> <td>○</td> <td>●</td> <td>○</td> <td>●</td> </tr> </tbody> </table>	[A]	[B]	[C]	[D]	○	●	○	●	
[A]	[B]	[C]	[D]						
○	●	○	●						
<p>Device versions: ● Recommended • Possible ○ Possible when the switching output is not used - Not possible</p>									

System code number 35

- Fixed set point/follow-up control
- Return flow temperature limitation
- Digital input e.g. for control according to day or night mode
- Switching output e.g. for pump control

Device version:

[A]	[B]	[C]	[D]
-	-	o	•

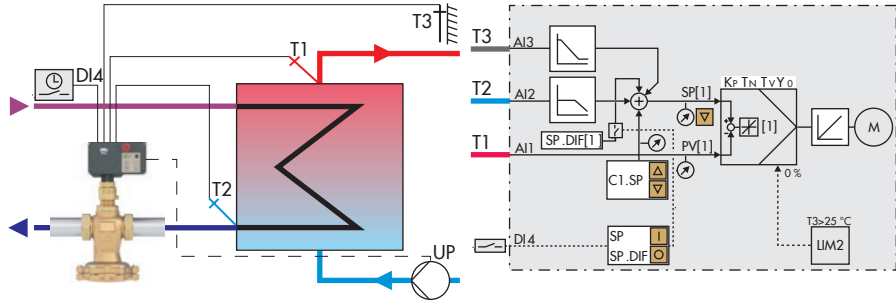

System code number 55

- Override control with minimum selection
- Return flow temperature limitation
- Digital input e.g. for control according to day or night mode
- Switching output e.g. for pump control

Device version:

[A]	[B]	[C]	[D]
-	-	o	•

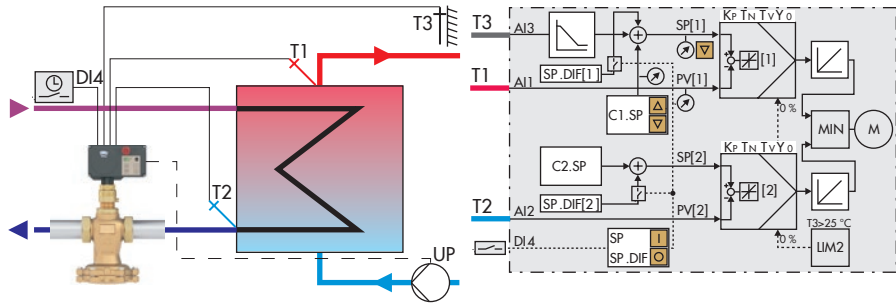

System code number 70

- Cascade control
- Two sensors and set point limitation at the input of the slave controller
- Switching output e.g. for pump control

[A]	[B]	[C]	[D]
o	•	o	•

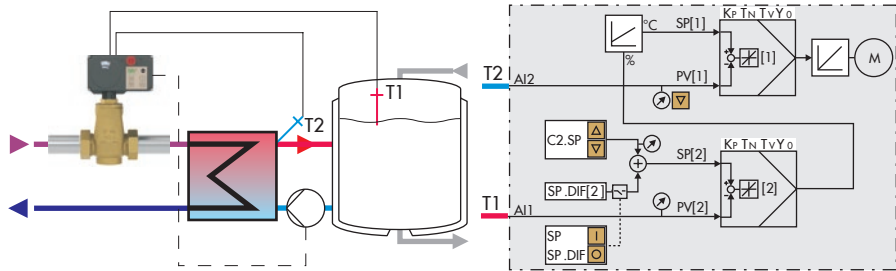

System code number 95

- Position transmitter 2 to 10 V
- Fixed set point control
- Return flow temperature limitation
- Switching output e.g. for pump control

[A]	[B]	[C]	[D]
-	-	o	•

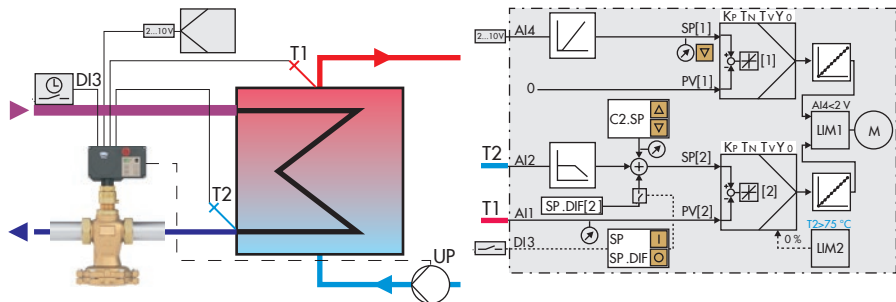

Device versions: • Recommended • Possible o Possible when the switching output is not used - Not possible

System code numbers for cooling applications

<p>System code number 20</p> <ul style="list-style-type: none"> Fixed set point control Differential temperature between two sensors <p>Device version:</p> <table border="1"> <thead> <tr> <th>[A]</th> <th>[B]</th> <th>[C]</th> <th>[D]</th> </tr> </thead> <tbody> <tr> <td style="text-align: center;">•</td> <td style="text-align: center;">•</td> <td style="text-align: center;">•</td> <td style="text-align: center;">•</td> </tr> </tbody> </table>	[A]	[B]	[C]	[D]	•	•	•	•	
[A]	[B]	[C]	[D]						
•	•	•	•						
<p>System code number 60</p> <ul style="list-style-type: none"> Override control with minimum selection Differential temperature between two sensors and return flow temperature limitation <p>Device version:</p> <table border="1"> <thead> <tr> <th>[A]</th> <th>[B]</th> <th>[C]</th> <th>[D]</th> </tr> </thead> <tbody> <tr> <td style="text-align: center;">•</td> <td style="text-align: center;">•</td> <td style="text-align: center;">•</td> <td style="text-align: center;">•</td> </tr> </tbody> </table>	[A]	[B]	[C]	[D]	•	•	•	•	
[A]	[B]	[C]	[D]						
•	•	•	•						
<p>System code number 65</p> <ul style="list-style-type: none"> Override control with minimum selection Differential temperature between two sensors and return flow temperature limitation External set point over 0 to 10 V signal <p>Device version:</p> <table border="1"> <thead> <tr> <th>[A]</th> <th>[B]</th> <th>[C]</th> <th>[D]</th> </tr> </thead> <tbody> <tr> <td style="text-align: center;">-</td> <td style="text-align: center;">-</td> <td style="text-align: center;">•</td> <td style="text-align: center;">•</td> </tr> </tbody> </table>	[A]	[B]	[C]	[D]	-	-	•	•	
[A]	[B]	[C]	[D]						
-	-	•	•						
<p>System code number 21</p> <ul style="list-style-type: none"> Fixed set point control Mean value calculation using two sensors Switching output e.g. for pump control <p>Device version:</p> <table border="1"> <thead> <tr> <th>[A]</th> <th>[B]</th> <th>[C]</th> <th>[D]</th> </tr> </thead> <tbody> <tr> <td style="text-align: center;">○</td> <td style="text-align: center;">•</td> <td style="text-align: center;">○</td> <td style="text-align: center;">•</td> </tr> </tbody> </table>	[A]	[B]	[C]	[D]	○	•	○	•	
[A]	[B]	[C]	[D]						
○	•	○	•						
<p>Device versions: • Recommended • Possible ○ Possible when the switching output is not used - Not possible</p>									

System code number 66

- Override control, district cooling with three sensors and a digital input
- Set point control with maximum selection

Device version:

[A]	[B]	[C]	[D]
-	-	•	•

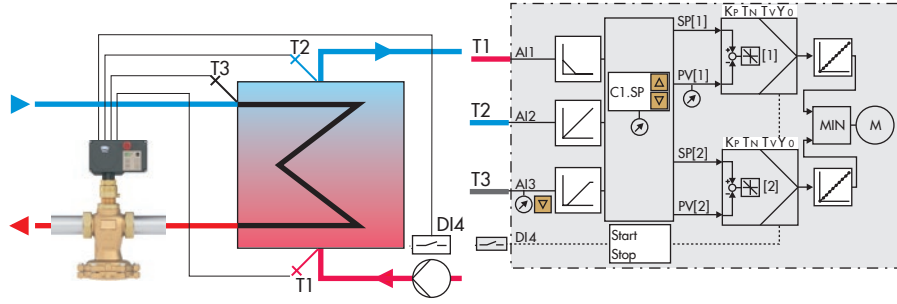

System code number 80

- Cascade control
- Two sensors and set point limitation at the input of the slave controller
- Switching output e.g. for pump control

Device version:

[A]	[B]	[C]	[D]
o	•	o	•

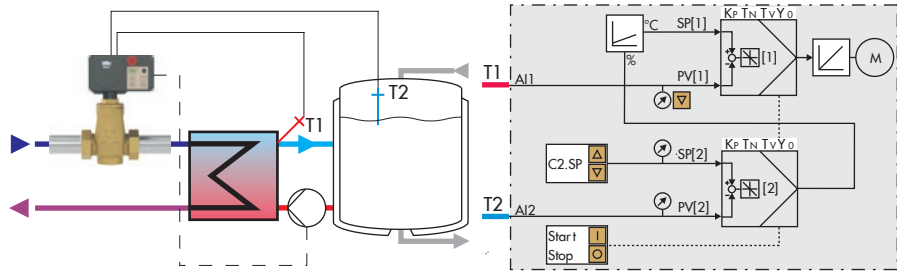

Device versions: • Recommended • Possible o Possible when the switching output is not used - Not possible

Technical data

Electric actuator with process controller	TROVIS	5724-810	5725-810	5724-820	5725-820	5724-830	5725-830
Fail-safe action		Without	With	Without	With	Without	With
Actuator stem		–	Extends	–	Extends	–	Extends
Connection to valve	Force-locking				Form-fit		
Rated travel	6 mm		12 mm		15 mm		
Transit time for rated travel	35 s		70 s		90 s		
Stroking speed	0.18 mm/s						
Thrust	700 N	500 N	700 N	500 N	700 N	280 N	
Power supply (depending on version)	230 V (±10 %), 50 Hz · 220 V (±10 %), 60 Hz ¹⁾ · 120 V (±10 %), 60 Hz						
Power consumption	5 VA						
Manual override	With	Without	With	Without	With	Without	
Permissible temperatures ²⁾							
Ambient	0 to 50 °C						
Storage	–20 to 70 °C						
Degree of protection (not installed suspended)	IP 54						
Electromagnetic compatibility	Acc. to EN 61000-6-2, EN 61000-6-3 and EN 61326						
Connecting cable length	Two-wire, 5 m · Three-wire, 2.5 m						
Weight	Approx. 1.1 kg						
Compliance							
Device version	[A], [B], [C], [D]						

¹⁾ Increased noise emissions

²⁾ The permissible medium temperature depends on the valve on which the electric actuator is mounted. The limits specified in the valve documentation applies.

Sensor		
Type	5277-2	5277-3
Number of Pt 1000 resistors	1	1
Sensor length	50 mm	50 mm
Perm. temperature range	–50 to 180 °C	
Degree of protection acc. to EN 60529	IP 54	
Weight	Approx. 0.23 kg	
Connecting cable length	2 m	3 m
Marking	Blue	Red
Wiring	AI2	AI1

Connecting cable		
Version	Two-wire	Three-wire
Length	5 m	2.5 m
Wire coding	N ↔ Blue L ↔ Brown	N ↔ Blue L ↔ Brown L' ↔ Black

Switching output	
Amperage	Max. 1 A
Voltage	Depending on power supply: 230 V · 120 V

Control line		
Version	AI3	AI4
Wire coding	+ ↔ Orange – ↔ Brown	+ ↔ Red – ↔ Black

Specifications subject to change without notice



SAMSON AG · MESS- UND REGELTECHNIK
Weismüllerstraße 3 · 60314 Frankfurt am Main, Germany
Phone: +49 69 4009-0 · Fax: +49 69 4009-1507
samson@samson.de · www.samson.de

T 5724-8 EN

2015-11-03 · English