



Trunnion mounted ball valves



**Our valve technology experts
are at your service when you
are choosing the right valve
solutions for your needs!**



Vexve – Inspired by your flow

Vexve is the leading European provider of valve solutions for the energy sector and selected energy-intensive industries.

The company is known for its superior product quality, the expertise of its personnel, and reliability as a partner. Vexve delivers its products to over 70 countries and employs over 700 people with factories in Finland, Czech Republic, Germany and China. Vexve aims to be the leading provider of mission-critical valve solutions in the transition to a low-carbon future.

Under the product brand Vexve Armatury we produce specialised, highly sophisticated valves for Gas & Hydrogen, Power, and Iron & Steel industries. The valves are designed according to the customer specifications taking into account the demanding operating requirements and highest safety standards.

The products are manufactured in our modern factory in Dolni Benesov, Czech Republic. We are specialized in valves for high pressure and temperatures. Products can be manufactured according to different standards such as EN, ASME and GOST.

The manufacturer of Vexve Armatury products is ARMATURY Group a.s., a part of the Vexve company.

Our extensive sales and distribution network covers more than 70 countries!

Content

General information (application, technical description)	4
Trunnion mounted ball valves, Split body K92.1	9
Trunnion mounted ball valves, Fully welded body K92.2	11
Trunnion mounted low pressure ball valves K92.4	14
Research and development	17
References	18
Type number composition	19

Application

Ball valves are designed to open fully or close fully the passage for a fluid in the piping system. They find their application in power engineering, Water - supply engineering, paper industry, chemical and petrochemical industries, in cryogenic applications, etc. Some design configurations enable to use the valves for short-time throttling. However, the process of throttling in combination with a service fluid containing mechanical impurities can result in loss of tightness of the valve obturator.

Design pressure is from 0 to the specified pressure class (Class, PN) for the relevant body material and sealing elements used.

Design temperature

Ambient temperature ranges from -60 °C to +80 °C.

Temperature of the service fluid can range from -46°C to 220°C.

Working medium

- gas
 - water
 - petroleum
- other service fluids by agreement with the manufacturer

Technical description

The ball valve design meets the requirements of API Spec 6D, EN 14313 and EN 14141 as well as those of the related normative documents. The valve construction has been tested in accordance with relevant normative documents and special regulations for fire safety (FIRE SAFE), resistance to wear caused by clean gas and wear in contaminated service, low emission EN 15848 (TA – Luft), seismic resistance, climatic resistance, functional safety (SIL), etc.

Body construction

The valve body is made of forgings. The bodies of ball valves NPS 2" to 4" consist of two pieces, the bodies of bigger ball valves consist of three pieces. The body parts are connected:

- in a dismantlable way by means of bolted joints to make a SPLIT BODY (SB), see Fig. 1, or screwed body (Fig. 2)
- in an indivisible way by means of welded joints to make a FULLY WELDED BODY (FW), see Fig. No. 3

The body construction, in combination with non-destructive tests and examinations of the body parts, guarantees constant external tightness of the valve body.

Ball construction

The ball is made of a single piece of wrought material. In order to make the ball surface resistant to wear and damage, the body surface can be plated with different materials depending on the fluid, such as ENP, ENP + Si, weld deposited with Stellite, F 316, Inconel, etc., or sprayed with TCC, etc. The ball is possible to seat on the trunnion plate or trunnion stem.

Fig. 1

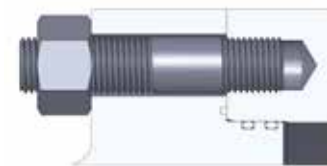

Fig. 2

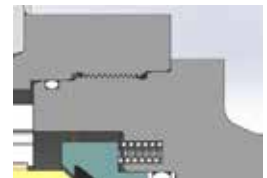

Fig. 3



Production range

Class/PN	NPS / DN									
	1 1/2"	2"	3"	4"	6"	8"	10"	12"	14"	16"
	40	50	80	100	150	200	250	300	350	400
150/16 a 25
300/40
400/63
600/100
900/160
1500/250
2500/400

Class/PN	NPS / DN										
	18"	20"	24"	28"	30"	34"	36"	40"	42"	48"	56"
	450	500	600	700	750	850	900	1000	1050	1200	1400
150/16 a 25
300/40
400/63
600/100
900/160
1500/250

Seat construction

Fig.	Type of seat	Description	Fluid	Temperature of the working medium	Working pressure	Material of seat insert	Seals
3a	Seat PMSS with elastomer and thermoplastic	Metallic contact between the seat and the ball guarantees protection of secondary seals that are made of thermoplastics and elastomers.	Gases with defined content of mechanical impurities.	* from -46°C to 220°C	class 150-900 (PN 16-160), up to class 1500 (PN 250) only to NPS 6 (DN 150)	POM, PEEK, HNBR, VITON	HNBR, VITON
3b	Seat with thermoplastic	Metallic contact between the seat and the ball provides protection of thermoplastic.	Liquids and gases with defined content of mechanical impurities.	* from -46°C to 220°C	class 150-2500 (PN 16-420)	RPTFE, PEEK	HNBR, VITON
3c	Metal-to-metal seated seat	Seating surfaces of the seat and the ball are sprayed with hard metal. The surfaces are lapped together to achieve the required tightness.	Contaminated gases and liquids, mixtures of solids and liquids.	* from -46°C to 220°C	class 150-1500 (PN 16-250)	metal+TCC – metal+TCC	HNBR, VITON, GRAFIT
	**Special seats	Depending on the fluid and the service parameters, also special designs of seats are available.	Steam, sea water, chemical compounds, etc.	acc. to request	acc. to request	Elastomers and thermoplastics of various types (NYLON, DEVLON).	Elastomers of other types, graphite boxes.

*Temperature range of the ball valve depends on the material of the seat insert and the material of seals.

For temperature of the working medium above 200 °C is the limit value of pressure related to the quality of the material of body acc. to ANSI B16.34 or EN 1092-1

**The design of the special seat is always a part of the drawing documentation submitted with the quotation.

Basic types of seats for Trunnion Mounted Ball Valves

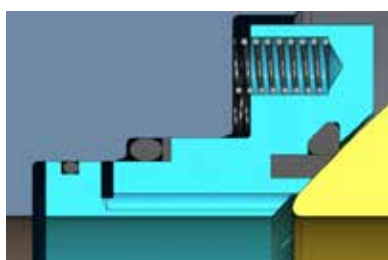

K92. x 4

Fig. 3a
Seat PMSS with elastomer and thermoplastic

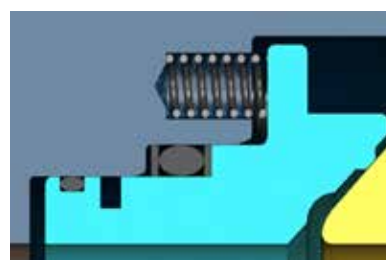

K92. x 2

Fig. 3c
Metal-to-metal seated seat

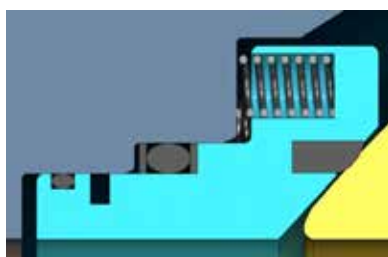

K92. x 1

Fig. 3b
Seat with thermoplastic

All types of seats can have alternatively two functional arrangements:

SINGLE PISTON EFFECT (SPE)

The seats with the SINGLE PISTON EFFECT are self-relieving – the increased pressure of the fluid in the body cavity is automatically relieved to the valve bore.

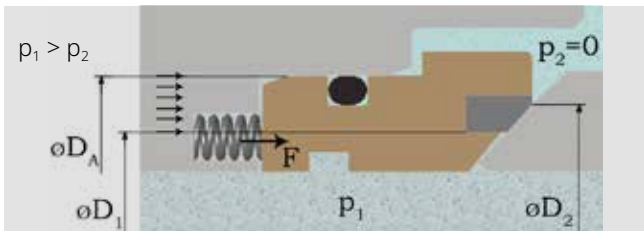

The seat is pushed against the ball permanently by the spring force (F) and by the piston effect - from the overpressure of the fluid in the valve bore acting on the annulus defined by ϕD_A and ϕD_1 .

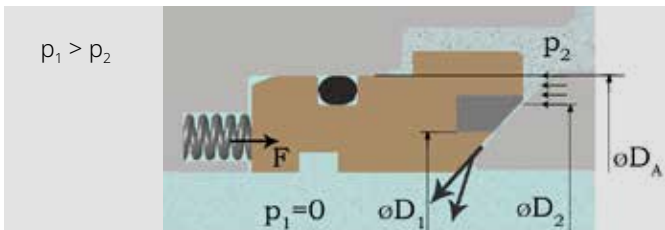

When the pressure of the fluid in the body cavity exceeds the pressure of the fluid in the valve bore, it means $p_2 > p_1$, the seat is pushed away from the ball

DOUBLE PISTON EFFECT (DPE)

The seat is pushed against the ball permanently by the spring force (F) and by the piston effect - from the overpressure of the fluid acting on the seat - regardless of whether the pressure of fluid acts only in valve bore or only in body cavity (this is a bidirectional, i.e. double piston effect) DIB - 1).

$p_1 > 0$

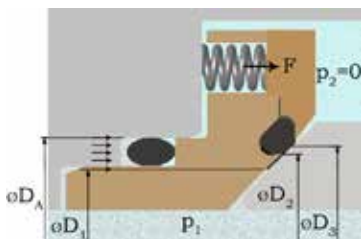

$p_2 > 0$

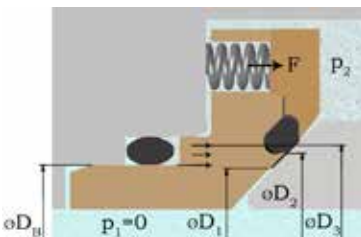

The seats with DOUBLE PISTON EFFECT are not self-relieving

Stem construction and assembly

The standard design of the stem support meets the ANTI BLOW OUT requirements (the stem cannot be ejected from the valve body by pressure of the fluid). The stem is both radially and axially supported so that no load is applied to the sealing rings. The stem is sealed with several seals that are independent of each other, from which the uppermost one is a firesafe seal. Ball valves in sizes DN 150 and over can be equipped with emergency sealant injection to the stem upon request. Typical design of the stem assembly and support is shown in Fig. No. 4.

Specification of additional design features

The ball valve is usually a valve with two seating surfaces (seats) which, in the closed position, provides a seal against pressure from both ends of the valve with a means for bleeding the cavity between the seating surfaces.

Body cavity pressure relief

This feature is used for fluids that are expanding when exposed to increased temperature.

The pressure relief can be done in several ways:

- Utilization of seats with SINGLE PISTON EFFECT (SPE)
- Utilization of seats arranged as follows: one seat with SINGLE PISTON EFFECT (SPE) and the other seat with DOUBLE PISTON EFFECT (DPE) DIB - 2
- Utilization of a pressure relief device

Antistatic design (ANTISTATIC)

This design provides for electrical continuity (conductive interconnection) between the ball, the stem and the body of the ball valve, see Fig. No. 5.

Fig. 4

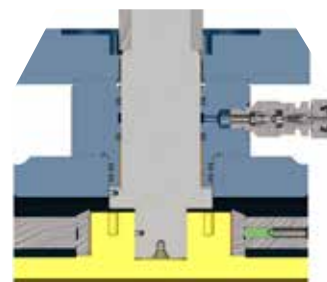
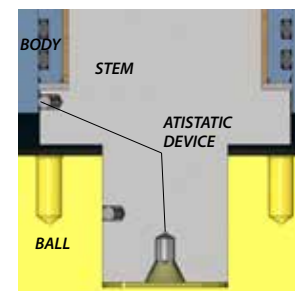

Fig. 5



Emergency sealant injection to seats



Emergency sealant injection to stem



Fire safety (FIRE-SAFE)

Fire safety has been proved for many ball valves according to the following standards: API 607, API 6FA, ISO 10497, BS 6755, and STO 2-4.1-212-2008.

Seismic and vibration resistance

Resistance has been proved by special tests according to GOST 30546.

Design according to EN 15848 (TA-Luft)

This design guarantees resistance to emission effects.

Service safety

The ball valves have been checked for service safety SIL 2 and SIL 3 according to ČSN EN 61508 -1,2 a 6 -2011.

Possible ball valve accessories

- draining
- venting
- sealant injection to seats
- sealant injection to stem
- stem extension - Fig. 6
- underground set
- relief device
- pups

Some of the above accessories are standard features of the ball valves, some of them shall be ordered by the customer.

Operation

- manual (lever, T-wrench)
- gearbox
- electric actuator
- pneumatic, hydraulic, electrohydraulic actuator
- other

Testing

according to ASME, EN or other standards)

The ball valves are subjected to the following tests:

- pressure tests
- functional and operability tests
- non-destructive tests and examinations

The scope of testing is specified by requirements of the customer. Inspection certificates according to EN 10204, type 3.1 or type 3.2.

Connection to the piping

- flanged ends (RF, RTJ) according to ASME B16.5, ASME B16.47, EN 1092-1, GOST 33259
- butt-welding ends (BW) according to ASME B16.25 or EN 12 627
- flanged ends with counter flanges, bolting material and sealing elements
- butt-welding ends with pup pieces
- combined with one flanged end and one welding end

Minimum valve bore

- full bore according to API Spec. 6D/ ISO 14313
- reduced bore according to API Spec. 6D/ ISO 14313 with bore reduction as required by the customer

Face-to-face and end-to-end dimensions according to:

- API Spec. 6D / ISO 14313
- ASME B16.10
- EN 558-1 (flanged ends)
- EN 12982 (butt-welding ends)

Installation

Ball valves may be installed into any piping (horizontal, vertical, inclined), but taking account of instructions applicable to installation of the actuator. Ball valves DN \geq 150 are equipped with a foundation plate and lifting eyes as a standard..

Advantages

- many variants of design configurations
- full and smooth bore resulting in very low pressure loss and piggability
- long-term reliability and maintenance-free service
- possibility of using of different actuators with attachment according to ISO 5211
- stiffness and compactness of construction and ability to transfer external forces

Materials

The selection of materials of individual components depends on service conditions (fluid, pressure, temperature).

For pressure-containing parts within the meaning of definition in API 6D, inspection certificates 3.1 according to EN 10204 are used as a standard or inspection certificates 3.2 according to EN 10204 upon request. For other materials, inspection certificates according to manufacturer's standard or customer's specification are used.

Design variants:
SPLIT BODY
FULLY WELDED BODY

Connection:

- ⊕ ASME B16.5, EN 1092-1 FLANGED ENDS
- ⊗ ASME B16.25, EN 12 627 WELDED ENDS

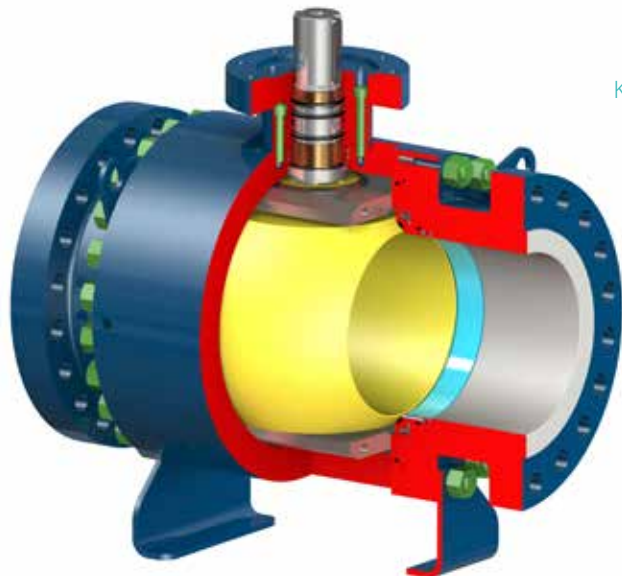

K92.1 - SPLIT BODY

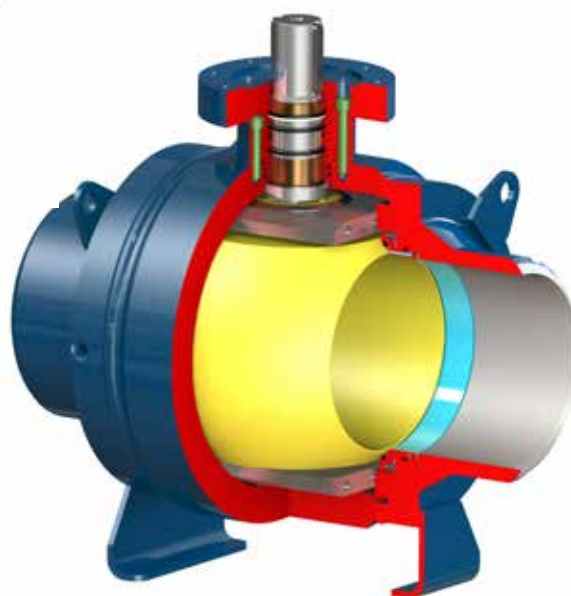

K92.2 - FULLY WELDED BODY

Materials

Component	Standard materials	Other materials
	Carbon steel For normal temperatures from -46°C to +220°C	
Body Bonnet	A350 LF2	A105, A694 F52 to 70, 1.4301, 1.4541, A182 F304, 1.4571, A182 F316, A182 F51
Ball - basic material	A350 LF2	A105, A182 F6a, 1.4301, 1.4541, A182 F304, 1.4571, A182 F316, A182 F51
Stem	AISI 4140 (42CrMo4) + ENP	1.7225, 1.4021, 1.4923, A182 F6a, 1.4301, 17-4 PH, 1.4542, 1.4571, A182 F304, A182 F316, A182 F51, A276 410, A276 420
Seat - basic material	A350 LF2	A182 F304, A182 F316, A182 F51
Seat and ball - surface	ENP	ENP+SiC, overlay STELLITE, overlay TCC
Bolt	A320 L7	A193 B7, A193 B7M, A193 B8, A320L7M
Nut	A194 Gr.4	A194 2H, A194 2HM, A194 7, A194 7M, A194 Gr.8, A194 8M
Seat inserts	PEEK	NYLON, DEVLON
Seals	HNBR or VITON	KALREZ, LIPSEAL

*Material with the notch toughness test at -60°C.
Other material variants on request.

Trunnion mounted ball valves, Split body

Type K92.1

NPS 2"-56" • Class 150-2500 • DN 50-1400 • PN 63-400
 Tmax 220 °C
 Design: SPLIT BODY

Connection:

- ☉ ASME B16.5, EN 1092-1 FLANGED ENDS
- ☼ ASME B16.25, EN 12 627 WELDED ENDS

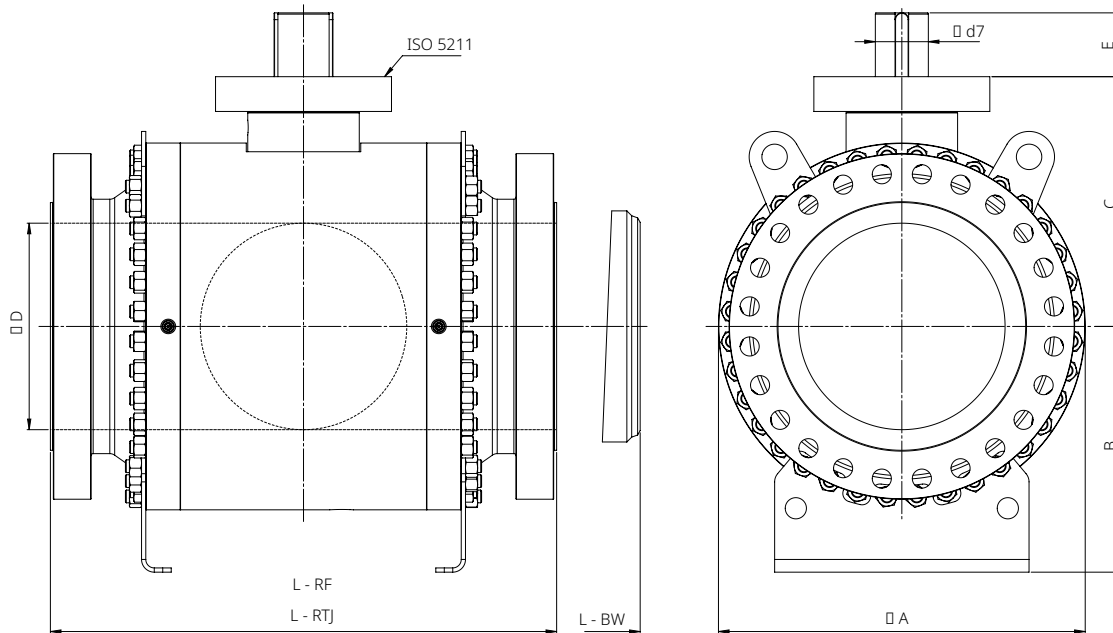

If another face to face dimension is required, which is not stated in the charts then it is agreed mutually.
 B and C dimensions are informative only, final dimensions based on requested accessories.

Class 400-600 • PN 63-100

NPS / DN	Dimensions [mm]									ISO 5211	° kg	
	ØD	L _{RF}	L _{BW}	L _{RTJ}	ØA	B	C	E	Ød ₇		RF	BW
2" / 50	49	292	292	295	185	112	129	35	27	F10	33	28
3" / 80	74	356	356	359	238	119	180	50	36	F12	69	66
4" / 100	100	432	432	435	265	132	188	50	38	F12	113	92
6" / 150	150	559	559	562	340	250	259	64	48	F14	248	197
8" / 200	201	660	660	664	425	302	321	75	58	F16	445	340
10" / 250	252	787	787	791	500	376	362	90	75	F25	702	545
12" / 300	303	838	838	841	580	420	404	90	75	F25	965	791
14" / 350	334	889	889	892	630	445	449	120	98	F30	1207	1074
16" / 400	385	991	991	994	705	487	489	120	98	F30	1620	1463
18" / 450	438	1092	1092	1095	780	477	498	126	98	F30	2038	1998
20" / 500	487	1194	1194	1200	865	580	589	151	125	F35	2909	2411
24" / 600	589	1397	1397	1407	1030	620	672	151	125	F35	4154	3976
28" / 700	684	1549	1549	1562	1150	680	717	185	125	F40	5700	5330
30" / 750	737	1651	1651	1664	1265	733	792	185	130	F40	6990	6450
32" / 800	781	1778	1778	1794	1365	783	815	245	150	F40	9040	8183
34" / 850	832	1930	1930	1946	1460	830	863	245	150	F48	10924	9450
36" / 900	876	2083	2083	2099	1510	905	892	225	150	F48	12183	10376
40" / 1000	978	2000	2000	-	1650	970	995	235	180	F48	14132	12910
42" / 1050	1022	2100	2100	-	1725	982	1013	265	180	F48	16975	15230
48" / 1200	1166	2400	2200	-	1930	1180	1148	265	180	F48	21180	19895
56" / 1400	1360	2540	2350	-	2240	1280	1318	241	200	F60	27320	25807

Trunnion mounted ball valves, Split body

Type K92.1

NPS 2"-56" • Class 150-2500 • DN 50-1400 • PN 63-400

Tmax 220 °C

Design: SPLIT BODY

Connection:

☉ ASME B16.5, EN 1092-1 FLANGED ENDS

☼ ASME B16.25, EN 12 627 WELDED ENDS

Class 900 • PN 160

NPS / DN	Dimensions [mm]									ISO 5211	° kg	
	øD	L _{RF}	L _{BW}	L _{RTJ}	øA	B	C	E	ød,		RF	BW
2" / 50	49	368	368	371	190	115	132	36	27	F12	58	40
3" / 80	74	381	381	384	238	119	191	50	36	F12	83	69
4" / 100	100	457	457	460	295	148	208	58	40	F14	129	112
6" / 150	150	610	610	613	340	250	276	73	58	F16	294	254
8" / 200	201	737	737	740	435	302	327	91	75	F25	516	462
10" / 250	252	838	838	841	500	376	362	91	75	F25	720	560
12" / 300	303	965	965	968	590	424	428	110	98	F30	1135	915
14" / 350	324	1029	1029	1038	640	431	454	120	98	F30	1420	1102
16" / 400	373	1130	1130	1140	730	487	502	120	98	F30	1863	1358
18" / 450	425	1219	1219	1232	808	524	509	130	98	F30	2850	2394
20" / 500	473	1321	1321	1334	889	565	539	150	125	F35	3780	3162
24" / 600	572	1549	1549	1568	1069	670	644	221	150	F40	5682	4671
28" / 700	665	1660	1600	1695	1310	825	784	200	150	F40	*	*
30" / 750	712	1880	1660	1902	1390	865	835	220	*	*	*	*
32" / 800	760	1850	1760	1885	1475	910	895	220	*	*	*	*
34" / 850	808	1950	1850	1992	1540	940	930	250	*	*	*	*
36" / 900	855	2286	1950	2315	1600	970	960	275	*	*	*	*
40" / 1000	956	1850	2000	-	1620	960	930	245	*	*	*	*
42" / 1050	1006	1900	2100	-	1690	965	1012	260	*	*	*	*
48" / 1200	1149	2400	2200	-	*	*	*	*	*	*	*	*
56" / 1400	1342	2540	2350	-	*	*	*	*	*	*	*	*

*These dimensions will be sent on request.

Class 1500 • PN 250

NPS / DN	Dimensions [mm]									ISO 5211	° kg	
	øD	L _{RF}	L _{BW}	L _{RTJ}	øA	B	C	E	ød,		RF	BW
2" / 50	49	368	368	371	190	115	134	36	27	F12	58	40
3" / 80	74	470	470	473	252	126	198	64	48	F14	115	88
4" / 100	100	546	546	549	295	140	208	58	40	F16	171	152
6" / 150	144	705	705	711	372	280	265	73	58	F16	407	330
8" / 200	194	832	832	841	536	388	350	96	75	F25	735	615
10" / 250	241	991	991	1000	652	446	427	96	75	F25	1120	925
12" / 300	289	1130	1130	1146	766	503	470	110	98	F30	1550	1300
14" / 350	318	1257	1257	1276	868	569	522	110	98	F30	1915	1600
16" / 400	362	1384	1384	1407	790	507	522	187	130	F35	3225	2650
18" / 450	407	1537	1537	1559	1090	680	650	185	125	F35	4300	3550
20" / 500	454	1664	1664	1686	1180	725	692	185	125	F35	5455	4515
24" / 600	546	1943	1943	1972	1415	858	817	260	170	F40	7860	6540

Class 2500 • PN 420

NPS / DN	Dimensions [mm]									ISO 5211	° kg	
	øD	L _{RF}	L _{BW}	L _{RTJ}	øA	B	C	E	ød,		RF	BW
2" / 50	42	451	451	454	230	175	182	50	40	F14	112	75
3" / 80	62	578	578	584	275	200	215	61	48	F16	212	135
4" / 100	87	673	673	683	315	215	250	76	58	F16	270	155
6" / 150	131	914	914	927	425	360	310	98	75	F25	755	505
8" / 200	179	1022	1022	1038	545	410	375	120	98	F30	1415	1110
10" / 250	223	1270	1270	1292	630	455	432	125	98	F30	2190	1510
12" / 300	265	1422	1422	1445	750	420	525	150	125	F35	3000	2020
14" / 350	292	-	1480	1630	805	600	575	160	130	F40	3700	3290
16" / 400	333	-	1540	1815	900	630	625	190	150	F40	560	4050

° Weights are informative only because of potential technological deviations.

Trunnion mounted ball valves, Fully welded body

Type K92.2

NPS 2"-56" • Class 150-2500 • DN 50-1400 • PN 16-400

Tmax 220 °C

Design: FULLY WELDED BODY

Connection:

☉ ASME B16.5, EN 1092-1 FLANGED ENDS

☼ ASME B16.25, EN 12 627 WELDED

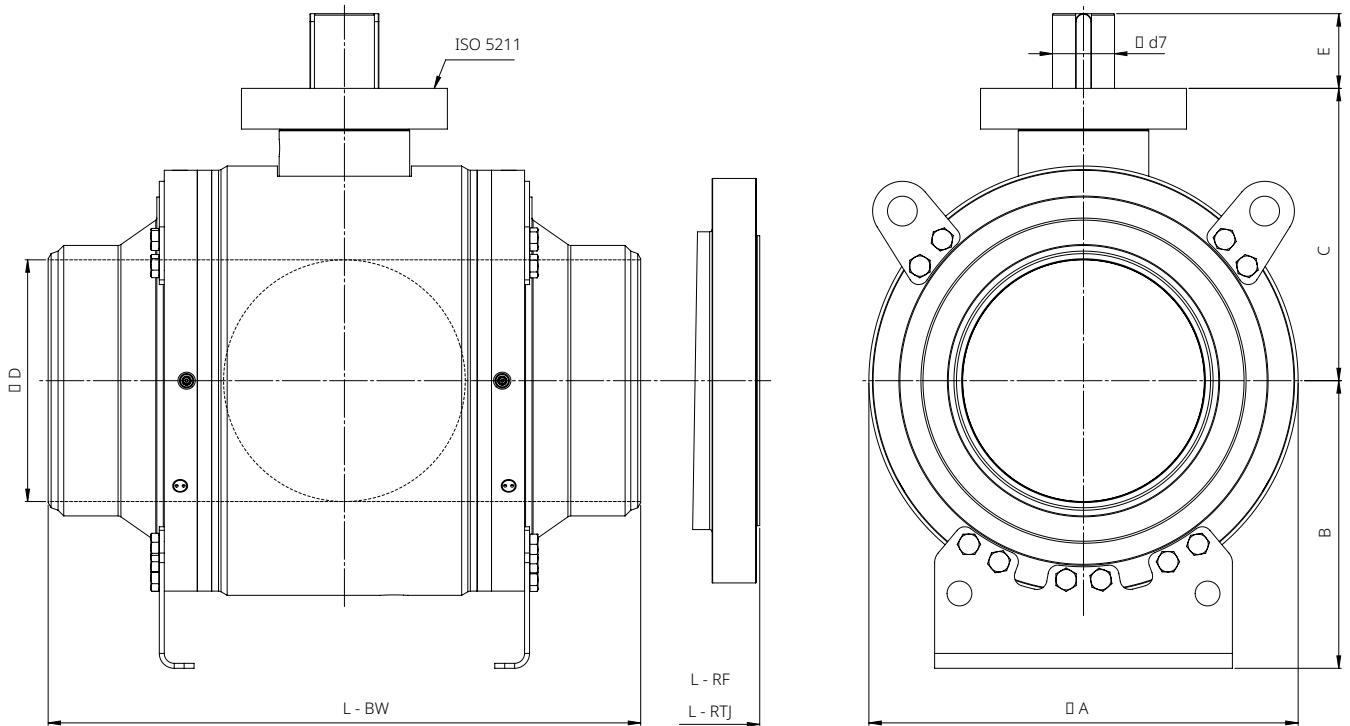

If another face to face dimension is required, which is not stated in the charts then it is agreed mutually.
B and C dimensions are informative only, final dimensions based on requested accessories.

Class 150-300 • PN 16-40

NPS / DN	Dimensions [mm]									ISO 5211	° kg	
	ØD	L _{RF}	L _{BW}	L _{RTJ}	ØA	B	C	E	Ød ₇		RF	BW
2" / 50	49	216	216	232	185	112	127	35	27	F10	28	22
3" / 80	74	283	356	298	238	110	180	50	36	F12	60	57
4" / 100	100	305	432	321	248	125	184	50	38	F12	82	75
6" / 150	150	457	559	419	340	250	259	64	48	F14	178	163
8" / 200	201	502	660	518	405	285	294	64	48	F14	297	298
10" / 250	252	568	787	584	480	340	350	77	58	F16	462	484
12" / 300	303	648	838	664	560	380	391	73	58	F16	662	657
14" / 350	334	762	889	778	630	425	425	90	75	F25	770	848
16" / 400	385	838	991	854	705	470	465	90	75	F25	1334	1250
18" / 450	438	914	1092	930	780	465	479	126	98	F30	1640	1834
20" / 500	487	991	1194	1010	865	575	538	120	98	F30	1960	2250
24" / 600	589	1143	1397	1165	1030	650	632	110	98	F30	2808	3685
28" / 700	684	1346	1549	1372	1180	684	717	151	125	F35	4120	4539
30" / 750	737	1397	1651	1422	1226	713	721	185	130	F40	5136	5850
32" / 800	781	1524	1778	1553	1325	763	775	185	130	F40	6230	7482
34" / 850	832	1626	1930	1654	1415	808	840	197	150	F40	7855	8650
36" / 900	876	1727	2083	1756	1500	900	849	225	150	F48	8966	9645
40" / 1000	978	1850	2000	-	1630	945	960	200	150	F40	10890	12024
42" / 1050	1022	1900	2100	-	1690	1040	1012	245	170	F40	13948	14497
48" / 1200	1168	2180	2100	-	1900	1160	1140	245	170	F48	17900	16750
56" / 1400	1362	2300	2250	-	2190	1280	1278	245	180	F48	23590	22415

Trunnion mounted ball valves, Fully welded body

Type K92.2

NPS 2"-56" • Class 150-2500 • DN 50-1400 • PN 16-400

Tmax 220 °C

Design: FULLY WELDED BODY

Connection:

☉ ASME B16.5, EN 1092-1 FLANGED ENDS

☼ ASME B16.25, EN 12 627 WELDED

Class 400-600 • PN 63-100

NPS / DN	Dimensions [mm]									ISO 5211	° kg	
	øD	L _{RF}	L _{BW}	L _{RTJ}	øA	B	C	E	ød ₇		RF	BW
2" / 50	49	292	292	295	185	112	129	35	27	F10	33	28
3" / 80	74	356	356	359	238	119	180	50	36	F12	69	57
4" / 100	100	432	432	435	248	130	188	50	38	F12	97	74
6" / 150	150	559	559	562	340	250	259	64	48	F14	224	163
8" / 200	201	660	660	664	425	310	321	75	58	F16	339	304
10" / 250	252	787	787	791	500	340	362	90	75	F25	580	499
12" / 300	303	838	838	841	580	380	404	90	75	F25	864	672
14" / 350	334	889	889	892	630	415	449	120	98	F30	980	948
16" / 400	385	991	991	994	705	469	489	120	98	F30	1503	1271
18" / 450	438	1092	1092	1095	780	465	498	126	98	F30	1950	1850
20" / 500	487	1194	1194	1200	865	580	589	151	125	F35	2528	2320
24" / 600	589	1397	1397	1407	1030	610	672	151	125	F35	4095	3656
28" / 700	684	1549	1549	1562	1180	684	752	185	125	F40	5046	4776
30" / 750	737	1651	1651	1664	1265	758	792	185	130	F40	6783	5678
32" / 800	781	1778	1778	1794	1365	783	815	245	150	F40	8687	7780
34" / 850	832	1930	1930	1946	1460	830	863	245	150	F48	10295	9095
36" / 900	876	2083	2083	2099	1500	900	928	225	150	F48	10671	9680
40" / 1000	978	2000	2000	-	1630	980	995	235	180	F48	13855	11624
42" / 1050	1022	2100	2100	-	1725	1060	1013	265	180	F48	16178	14875
48" / 1200	1168	2400	2200	-	1930	1180	1148	265	180	F48	21180	19895
56" / 1400	1362	2540	2350	-	2240	1280	1318	241	200	F60	27320	25807

Class 900 • PN 160

NPS / DN	Dimensions [mm]									ISO 5211	° kg	
	øD	L _{RF}	L _{BW}	L _{RTJ}	øA	B	C	E	ød ₇		RF	BW
2" / 50	49	368	368	371	190	115	132	36	27	F12	58	40
3" / 80	74	381	381	384	238	119	180	50	36	F12	83	60
4" / 100	100	457	457	460	295	130	205	58	40	F14	147	123
6" / 150	150	610	610	613	350	255	276	73	58	F16	293	182
8" / 200	201	737	737	740	440	330	332	91	75	F25	489	395
10" / 250	252	838	838	841	512	376	357	91	75	F25	664	549
12" / 300	303	965	965	968	598	407	434	110	98	F30	990	820
14" / 350	324	1029	1029	1038	640	431	454	120	98	F30	1220	950
16" / 400	373	1130	1130	1140	734	487	471	120	98	F30	1610	1150
18" / 450	425	1219	1219	1232	808	524	509	130	98	F30	2600	2140
20" / 500	473	1321	1321	1334	892	560	599	150	125	F35	3480	2730
24" / 600	572	1549	1549	1568	1069	670	644	221	150	F40	5230	4310
28" / 700	665	1660	1600	1695	1220	725	776	200	150	F40	*	*
30" / 750	712	1880	1660	1902	1390	865	835	220	*	*	*	*
32" / 800	760	1850	1760	1885	1475	910	895	220	*	*	*	*
34" / 850	808	1950	1850	1992	1540	940	930	250	*	*	*	*
36" / 900	855	2286	1950	2315	1600	970	960	275	*	*	*	*
40" / 1000	956	1850	2000	-	1620	960	930	245	*	*	*	*
42" / 1050	1006	1900	2100	-	1690	965	1012	260	*	*	*	*
48" / 1200	1149	2400	2200	-	*	*	*	*	*	*	*	*
56" / 1400	1342	2540	2350	-	*	*	*	*	*	*	*	*

*These dimensions will be sent on request.

Trunnion mounted ball valves, Fully welded body Type K92.2

NPS 2"-56" • Class 150-2500 • DN 50-1400 • PN 16-400
 Tmax 220 °C
 Design: FULLY WELDED BODY

Connection:

- ⊙ ASME B16.5, EN 1092-1 FLANGED ENDS
- ⊛ ASME B16.25, EN 12 627 WELDED

Class 1500 • PN 250

NPS / DN	Dimensions [mm]									ISO 5211	° kg	
	øD	L _{RF}	L _{BW}	L _{RTJ}	øA	B	C	E	ød ₇		RF	BW
2" / 50	49	368	368	371	190	115	134	36	27	F12	58	40
3" / 80	74	470	470	473	252	126	198	64	48	F14	115	88
4" / 100	100	546	546	549	280	140	215	58	40	F16	180	160
6" / 150	146	705	705	711	425	333	300	73	58	F16	400	330
8" / 200	194	832	832	841	536	388	350	96	75	F25	735	615
10" / 250	241	991	991	1000	652	446	427	96	75	F25	1120	925
12" / 300	289	1130	1130	1146	766	503	470	110	98	F30	1550	1131
14" / 350	318	1257	1257	1276	868	569	522	110	98	F30	1915	1600
16" / 400	362	1384	1384	1407	988	629	598	187	130	F35	2350	1950
18" / 450	407	1537	1537	1559	1090	680	650	185	125	F35	3300	2750
20" / 500	454	1664	1664	1686	1180	725	692	185	125	F35	4455	3715
24" / 600	546	1943	1943	1972	1415	858	817	260	170	F40	6660	5540

Class 2500 • PN 420

NPS / DN	Dimensions [mm]									ISO 5211	° kg	
	øD	L _{RF}	L _{BW}	L _{RTJ}	øA	B	C	E	ød ₇		RF	BW
2" / 50	42	451	451	454	230	175	182	50	40	F14	112	75
3" / 80	62	578	578	584	275	200	215	61	48	F16	212	135
4" / 100	87	673	673	683	315	215	250	76	58	F16	270	155
6" / 150	131	914	914	927	425	360	310	98	75	F25	755	505
8" / 200	179	1022	1022	1038	545	410	375	120	98	F30	1415	1110
10" / 250	223	1270	1270	1292	630	455	432	125	98	F30	2190	1510
12" / 300	265	1422	1422	1445	750	420	525	150	125	F35	3000	2020
14" / 350	292	-	1480	1630	805	600	575	160	130	F40	3700	3290
16" / 400	333	-	1540	1815	900	630	625	190	150	F40	560	4050

° Weights are informative only because of potential technological deviations.

Design variants:

- Full bore
- Reduced bore
- Long stem ball valve

Connection:

- ⊕ EN 1092-1 FLANGED ENDS
- ⊗ ASME B16.25, EN 12 627, EN 488 WELDED ENDS

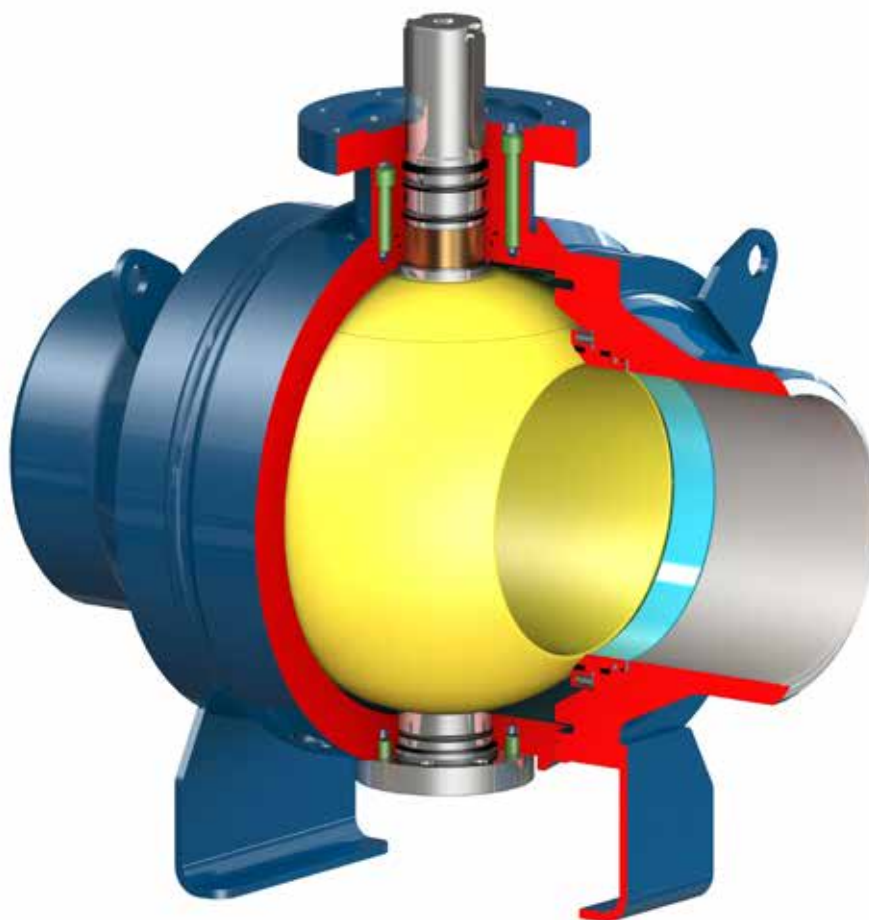

Materials

Component	Standard materials
	Carbon steel
	For normal temperatures from -40°C to +220°C
Body	
Bonnet	P355 QH/NH
Ball - basic material	A350LF2
Stem	1.4057 P800
Seat - basic material	A350LF2
Seat and ball - surface	50ENP
Bolt	A320L7
Nut	-
Seat inserts	RPTFE
Seals	VITON

*Material with the notch toughness test at -60°C.
Other material variants on request.

Trunnion mounted low pressure ball valves

Type K92.4

NPS 6"-48" • Class 150-300 • DN 150-1200 • PN 16-40
 Tmax 220 °C
 Design: FULLY WELDED BODY

Connection:

⊗ EN 1092-1 FLANGED ENDS

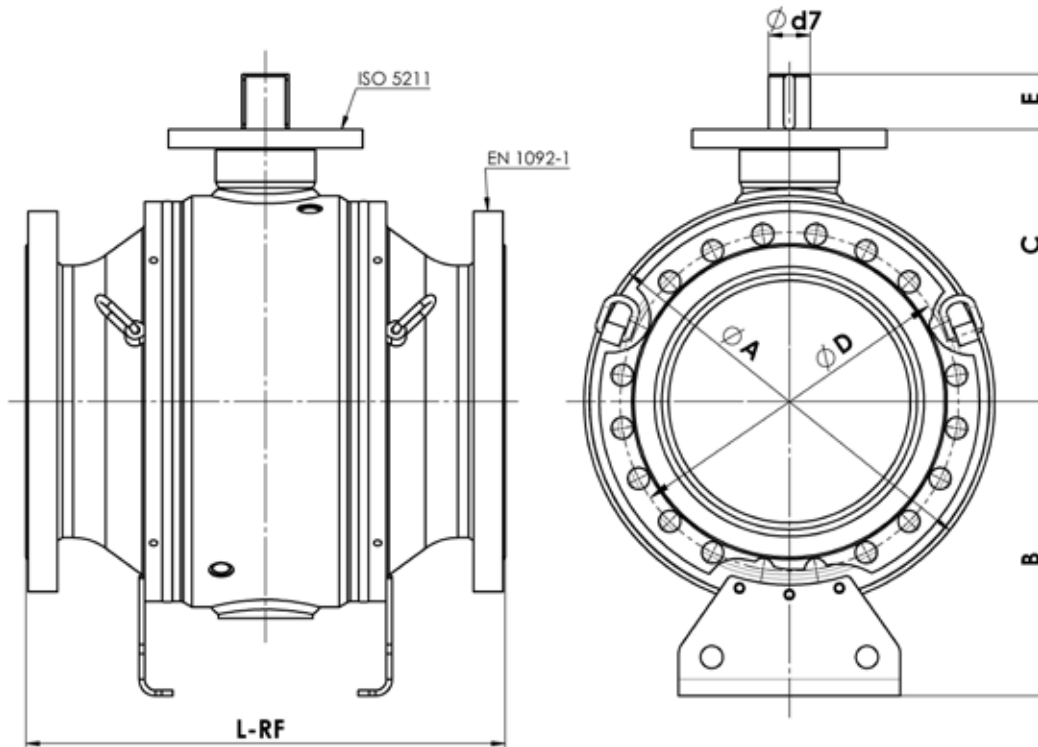

If another face to face dimension is required, which is not stated in the charts then it is agreed mutually.
 B and C dimensions are informative only, final dimensions based on requested accessories.

Class 150-300 • PN 16-25

NPS / DN	Dimensions [mm]									ISO 5211	kg	
	øD	L _{RF16}	L _{BW}	L _{RF25}	øA	B	C	E	ød ₇		RF PN16	RF PN25
2" / 50	49	216	216	232	185	112	127	35	27	F10	28	22
3" / 80	74	283	356	298	238	110	180	50	36	F12	60	57
4" / 100	100	305	432	321	248	125	184	50	38	F12	82	75
6" / 150	1150	457	559	419	340	250	259	64	48	F14	178	163
8" / 200	201	502	660	518	405	285	294	64	48	F14	297	298
10" / 250	1252	568	787	584	480	340	350	77	58	F16	462	484
12" / 300	303	648	838	664	560	380	391	73	58	F16	662	657
14" / 350	1334	762	889	778	630	425	425	90	75	F25	770	848
16" / 400	385	838	991	854	705	470	465	90	75	F25	1334	1250
18" / 450	436	864	-	864	740	530	490	100	75	F30	1047	1085
20" / 500	487	914	-	914	822	580	537	100	90	F30	1340	1381
24" / 600	589	1067	-	1067	980	660	616	121	98	F30	2164	2192
28" / 700	684	1245	-	1245	1125	700	722	130	98	F35	3207	3282
32" / 800	779	1372	-	1372	1290	840	833	140	120	F35	4855	4956
36" / 900	874	1524	-	1524	1440	900	908	140	120	F40	6216	6332
40" / 1000	976	-	-	-	1600	970	1010	180	135	F40	-	-
48" / 1200	1166	-	-	-	1900	1120	1160	205	140	F48	-	-

Also available in PN 40. For more information contact our sales department.
 Sizes DN 150 – 400 manufactured by Vexve, a member of Vexve Armatury Group.

Trunnion mounted low pressure ball valves

Type K92.4

NPS 6"-48" • Class 150-300 • DN 150-1200 • PN 16-40
 Tmax 220 °C
 Design: FULLY WELDED BODY

Connection:

☉ ASME B16.25, EN 12 627, EN 488 WELDED ENDS

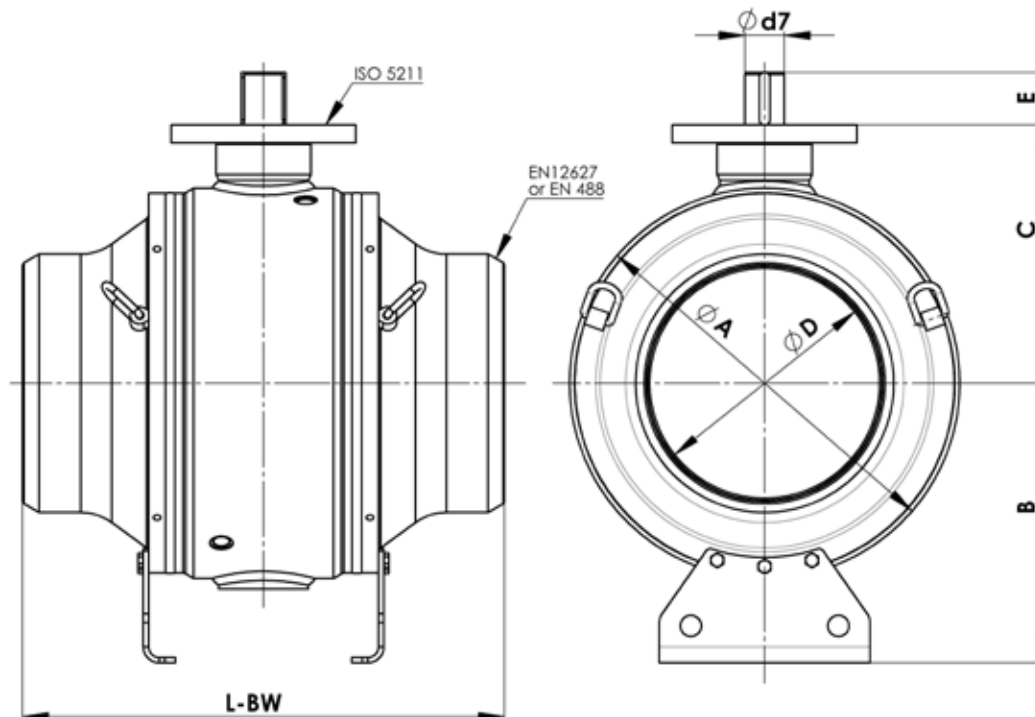

If another face to face dimension is required, which is not stated in the charts then it is agreed mutually.
 B and C dimensions are informative only, final dimensions based on requested accessories.

Class 150-300 • PN 16-25

NPS / DN	Dimensions [mm]									ISO 5211	kg BW
	øD	L _{RF}	L _{BW}	L _{RTJ}	øA	B	C	E	ød ₇		
2" / 50	49	216	216	232	185	112	127	35	27	F10	22
3" / 80	74	283	356	298	238	110	180	50	36	F12	57
4" / 100	100	305	432	321	248	125	184	50	38	F12	75
6" / 150	1150	457	559	419	340	250	259	64	48	F14	163
8" / 200	201	502	660	518	405	285	294	64	48	F14	298
10" / 250	1252	568	787	584	480	340	350	77	58	F16	484
12" / 300	303	648	838	664	560	380	391	73	58	F16	657
14" / 350	1334	762	889	778	630	425	425	90	75	F25	848
16" / 400	385	838	991	854	705	470	465	90	75	F25	1250
18" / 450	436	-	914	-	740	530	490	100	75	F30	996
20" / 500	487	-	991	-	822	580	537	100	90	F30	1271
24" / 600	589	-	1143	-	980	660	616	121	98	F30	2072
28" / 700	684	-	1346	-	1125	700	722	130	98	F35	3142
32" / 800	779	-	1524	-	1290	840	833	140	120	F35	4780
36" / 900	874	-	1727	-	1440	900	908	140	120	F40	6192
40" / 1000	976	-	2000	-	1600	970	1010	180	135	F40	8895
48"/1200	1166	-	2200	-	1900	1120	1165	205	140	F48	14080

Also available in PN 40. For more information contact our sales department.
 Sizes DN 150 – 400 manufactured by Vexve, a member of Vexve Armatury Group.

Research and development

As far as our research and development is concerned, there may be offered also special, non-traditional ball valves such as Twin ball valves (see Fig. No. 7), special ball valves used for monitoring and inlet cleaning equipment - Pig ball valves (Fig.8), Ball valves operated with hydro cylinder and counterweight (Fig. 9) or Ball valves with retractable seats K92.15 (Fig.10).

Typical curve of operating torques

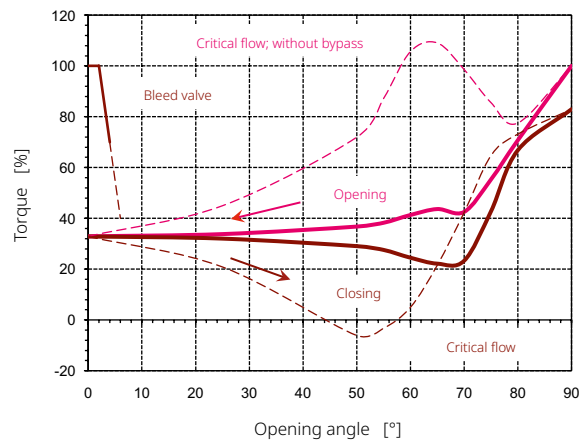

Flow characteristics

DN	40	50	80	100	150	200	250	300	350	400	450	500
NPS	1 1/2"	2"	3"	4"	6"	8"	10"	12"	14"	16"	18"	20"
Kv [m³/h]	150	250	760	1300	3300	6500	10700	16700	23500	31600	41100	51800
ζ [-]	0,18	0,16	0,11	0,09	0,07	0,06	0,05	0,05	0,04	0,04	0,04	0,04

DN	550	600	650	700	750	800	850	900	1000	1050	1200	1400
NPS	22"	24"	26"	28"	30"	32"	34"	36"	40"	42"	48"	56"
Kv [m³/h]	64000	77400	93200	109500	127000	144000	162000	181000	250000	279000	371000	536000
ζ [-]	0,04	0,03	0,03	0,03	0,03	0,03	0,03	0,03	0,03	0,02	0,02	0,02

Kv	[m³/h]	flow coefficient (EN 1267)
ζ	[-]	pressure loss coefficient (EN 1267)

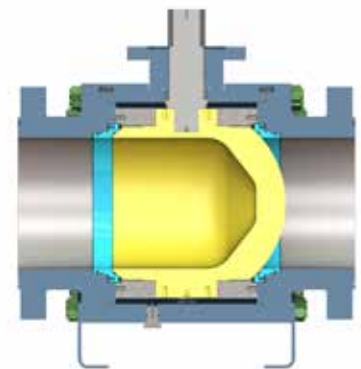

Fig. 8 Pig ball valve

FEM Analysis

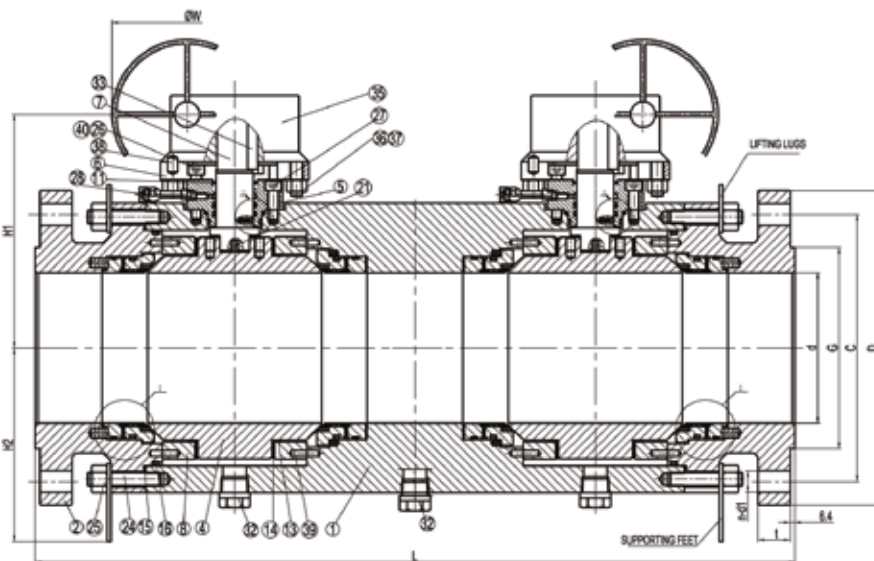
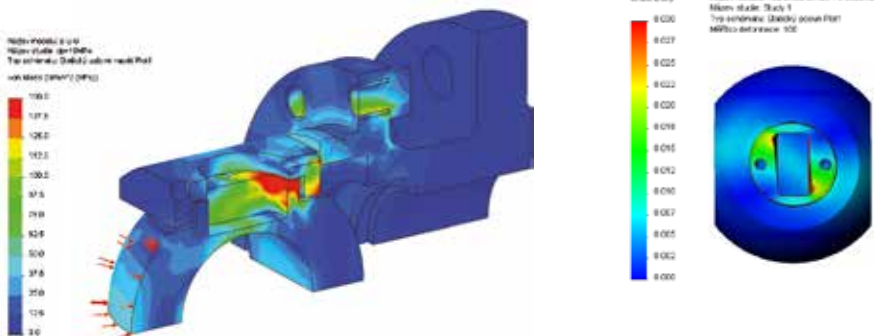

Fig. 7 Twin ball valve

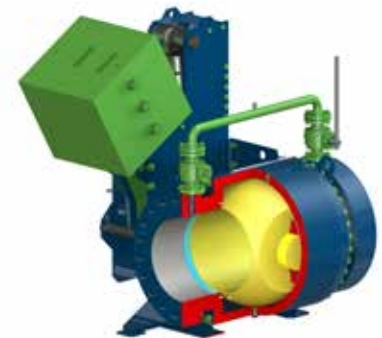

Fig. 9 Ball valve operated with hydro cylinder and counterweight



Fig. 10 Ball valve with retractable seats K92.15

Trunnion mounted ball valves

References



Construction of gas pipeline for Kalimantan Jawa Gas, Indonesia



Ball valve at the Norwegian Liarelva hydroelectric power plant



Installation of underground ball valves for Nafta a.s., Slovakia



Inspection of ball valves DN 1400 for Eustream, Slovakia



Automatic welding of ball valves DN 1400



Pressure test of ball valves at our workshop

Trunnion mounted ball valves

Type number composition

Type number uniquely describes the valve.

Type number is fixed by the manufacturer (supplier).

Type number serves to customers in subsequent communication with the manufacturer (supplier) valve.

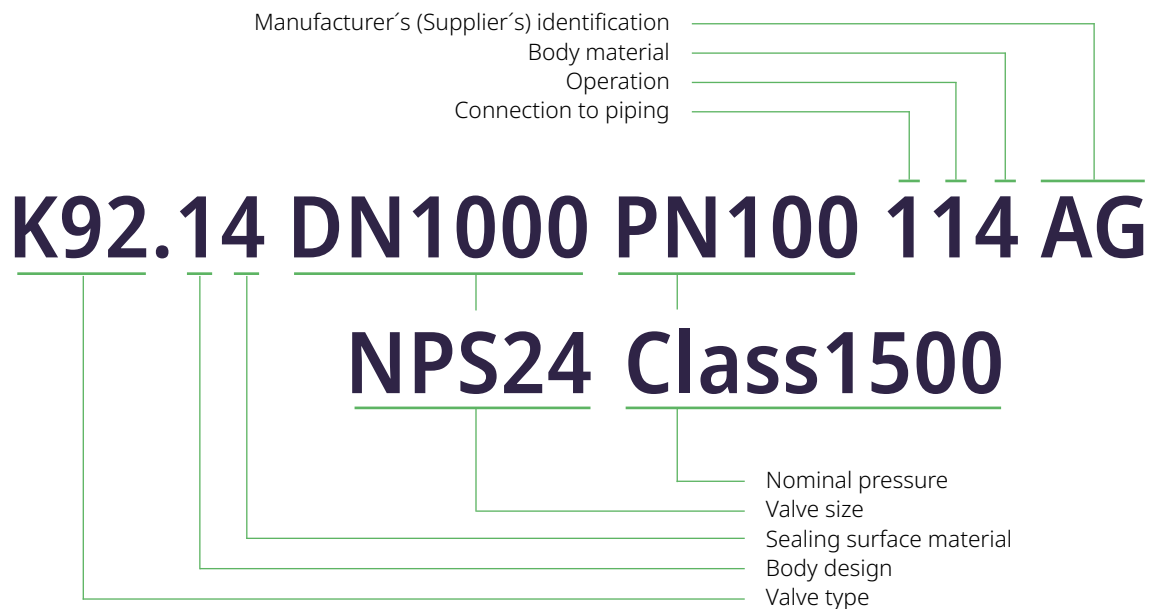

Valve type

K92 – trunnion mounted ball valve full or reduced bore

Body design

- 1 – forged body, SPLIT DESIGN
- 2 – forged body, FULLY WELDED DESIGN
- 4 – low pressure ball valves

Sealing surface material

- 1 – soft seated seats (PMSS with thermoplastic)
- 2 – metal x metal (Metal-to-metal seated seat)
- 3 – special (on request)
- 4 – combined
(Seat PMSS with elastomer and thermoplastic)
- 5 – retractable seats

Connection to piping

- 1 – flanged ends
- 2 – welded ends

Operation

- 1 – lever
- 2 – gear operator with handwheel
- 3 – electric actuator
- 4 – pneumatic, hydraulic, electro-hydraulic
or hydraulic-pneumatic actuator
- 5 – bare stem
- 6 – other
- 9 – lever with weight

Body material

- 0 – stainless steel
- 3 – forged alloy steel
- 4 – forged carbon steel

Manufacturer's (Supplier's) identification

AG – ARMATURY Group a.s.

Data mentioned in the catalogue are not subject to changes, for an order and delivery of the goods are obligatory the data mentioned in respective specifications.



Vexve Czechia
ARMATURY Group a.s.
Nádražní 129
747 22 Dolní Benešov
Czech Republic
armatury@vexve.com

