

# Mounting and Operating Instructions

## Solenoid Valves Type 3963



Fig. 1

### General



**Assembly, commissioning and operation of these devices may only be performed by experienced personnel. Proper shipping and appropriate storage are assumed.**

**The air supply must not exceed the maximum permissible pressure and, if necessary, it must be limited by a pressure reducer.**

The devices can be mounted in any desired position. The filter in the enclosure cover and the cable gland M 20 × 1.5 must be installed hanging downwards, or if this is not possible, horizontally.



**The required degree of protection according to IEC 60529:1989 can be only guaranteed with attached enclosure cover, integrated exhaust air filters and proper installation of the connections.**

On mounting, make sure that a clearance of minimum 300 mm above the enclosure cover is kept.

In locations where there is a risk of mechanical damage to the enclosure, the enclosure must be fitted with additional protection to fulfill the

requirements in paragraph 6 of EN 61241-0: 2006 ("Electrical apparatus for use in the presence of combustible dust").

If the device is mounted to a rotary actuator or linear actuator with positioner, it is necessary to change over the air supply to an external supply at connection 9 (see page 7 ff.).

The minimum permissible ambient temperature is  $-20^{\circ}\text{C}$  (Type 3963-XXXXXXXXXXXXX0) and  $-45^{\circ}\text{C}$  (Type 3963-XXXXXXXXXXXXX1).

The permissible ambient temperature is lowered for intrinsically safe devices in accordance with the EC Type Examination Certificate PTB 01 ATEX 2085 and the Statement of Conformity PTB 01 ATEX 2086 X (see pages 10 and 11).

Refer to Data Sheet T 3963 EN for technical data, ordering data, spare parts and accessories.

### Contents

General	Page 1
Mounting	Page 2
Air connection	Page 6
Electrical connection	Page 9
Approvals	Page 10

# Mounting

## Rail mounting

- ▶ Type 3963-XXX0011/-XXX0012/  
-XXX0111/-XXX1011/  
-XXX8011

These devices can be attached with two mounting bases for G-profile rail 32 according to EN 50035 or top hat rail 35 according to EN 50022 (Fig. 2).

## Wall mounting

- ▶ Type 3963-XXX0011/-XXX0012/  
-XXX0111/-XXX1011/  
-XXX8011

These devices can be attached to a wall mounting plate (Fig. 2).

- ▶ Type 3963-XXXX013/-XXXX014

These devices can be attached with screws through bore holes (Fig. 3).

### Mounting base for G-profile rail 32 (Order no. 1400-5930)

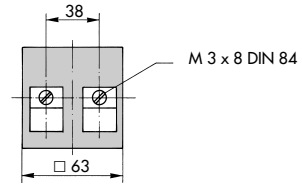

### Mounting base for top hat rail 35 (Order no. 1400-5931)

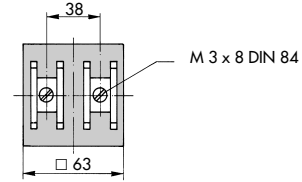

### Wall mounting plate (Order no. 1400-6726)

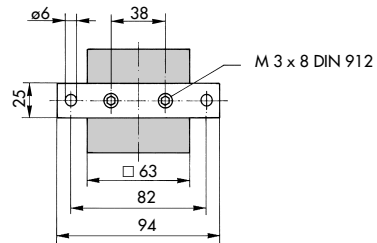
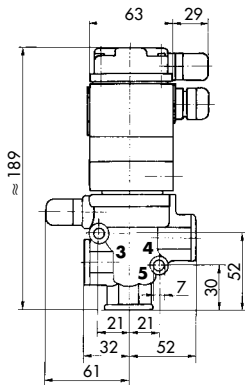

Fig. 2 · Dimensions in mm

## Type 3963-XXXX014



## Type 3963-XXXX013

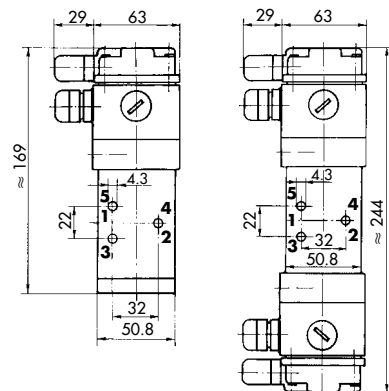

Fig. 3 · Dimensions in mm

**Mounting to rotary actuators with NAMUR interface according to VDI/VDE 3845**

► Type 3963-XXXXX0

These devices can be directly attached to rotary actuators with NAMUR interface (Fig. 4). Before mounting, check that the two O-rings are positioned correctly. The operation direction is determined by a threaded coding pin M 5 × 10 DIN 916 on the mounting flange of the rotary actuator. The device is attached with two screws M 5 × 35 ISO 4762. The mounting accessories are delivered together with the device.

**Mounting to restrictor block for single-acting rotary actuators with NAMUR interface according to VDI/VDE 3845**

► Type 3963-XXX1003

These devices can be attached to a restrictor block for rotary actuators with NAMUR interface (Fig. 5). The restricting function can be identified from the symbol indicated on the device. Different closing and opening times can be adjusted in a ratio of 1:15 by turning the restricting screws clockwise or counterclockwise with a screwdriver.

**NAMUR interface according to VDI/VDE 3845**

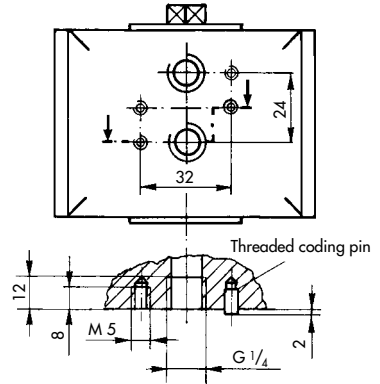

Fig. 4 · Dimensions in mm

**Mounting to restrictor block (Order no. 1400-6763) for single-acting rotary actuators**

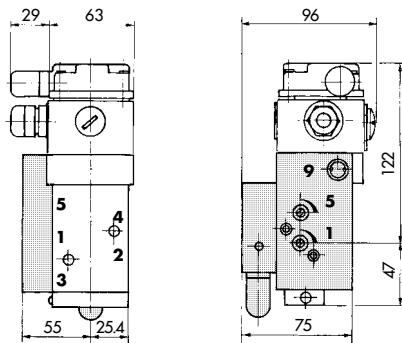

Fig. 5 · Dimensions in mm

### Mounting with adapter plate to linear actuators with NAMUR rib according to IEC 60534-6-1

#### ► Type 3963-XXX0X0

These devices can be mounted with an adapter plate (Fig. 6) to linear actuators with a NAMUR rib. When both a positioner and limit switch are to be mounted on linear actuators with nominal size  $\leq$  DN 50, a bracket (Order no. 0320-1416) is required.

### Mounting with CrNiMo steel pipe fittings to linear actuators

#### ► Type 3963-XXX0X1X0/-XXX0X142

These devices can be mounted using a CrNiMo steel pipe fitting to linear actuators, e.g. SAMSON Type 3271 or 3277 (Fig. 7). Refer to Mounting and Operating Instructions EB 8310 EN and EB 8311 EN.

### Adapter plate NAMUR rib/NAMUR interface (Order No. 1400-6751)

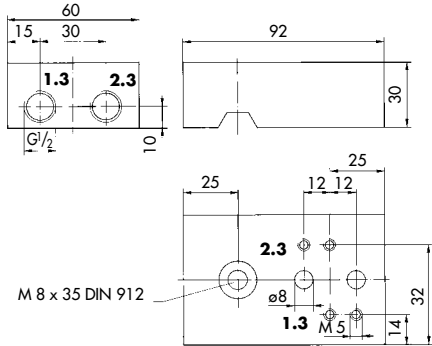
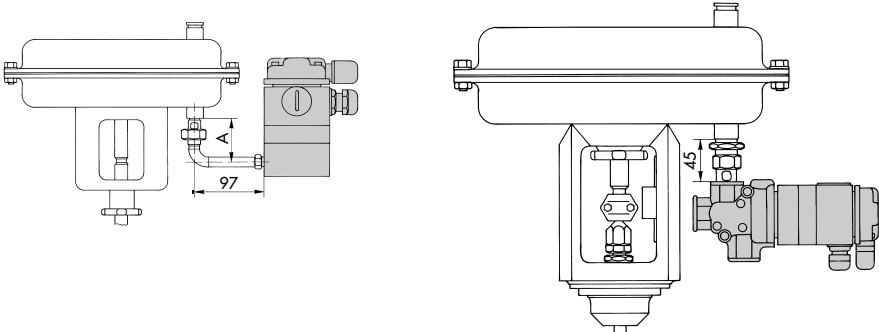

Fig. 6 · Dimensions in mm

### Mounting with CrNiMo steel pipe fittings to linear actuators



Actuator size	Connection	A	Order no.
80/240 cm <sup>2</sup>	G 1/4 / 1/4	64	<b>1400-6759</b>
350/700 cm <sup>2</sup>	G 3/8 / 1/4	75	<b>1400-6761</b>
	G 3/8 / 1/2	64	<b>1400-6735</b>

Actuator size	Connection	Order no.
1400 cm <sup>2</sup>	G 3/4 / 1/2	<b>1400-6736</b>
2100 cm <sup>2</sup>	G 1 / 1/2	<b>1400-6737</b>
2800 cm <sup>2</sup>		

Fig. 7 · Dimensions in mm

**Mounting to connection block for SAMSON Type 3277 Linear Actuator**

► Type 3963-XXX0X3

These devices can be mounted to a connection block for SAMSON Type 3277 Linear Actuator with SAMSON Type 3730-X, 3731-X, 3766, 3767 or 378X Positioner (Fig. 8). Before mounting, check that the four O-rings are positioned correctly on the mounting flange. The device is attached with two screws M 5 × 55 ISO 4762. The mounting accessories are delivered together with the device. Refer to mounting and operating instructions of the corresponding SAMSON devices.

**Mounting to linear actuators with NAMUR rib according to IEC 60534-6-1**

► Type 3963-XXX002

This device can be directly mounted to a linear actuator with NAMUR rib. The device is attached with a screw M 8 × 35 ISO 4762 which is delivered with the device.

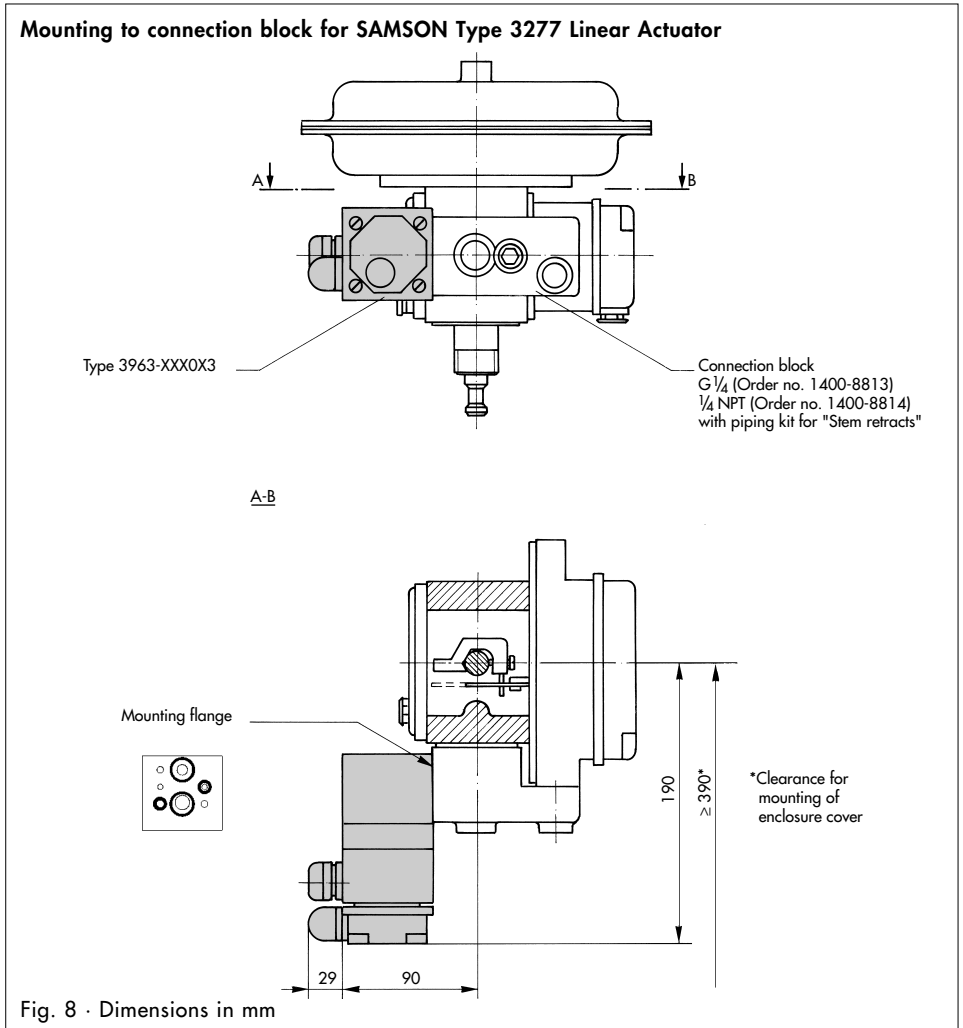

## Air connection



The air supply pipes and screw fittings must be mounted by experienced personnel only.

They must be regularly checked for leakage and damage, and if necessary, repaired. Before starting any repair work, all supply pipes which are to be opened must be depressurized.

The air connections are G (NPT)  $\frac{1}{4}$  or G (NPT)  $\frac{1}{2}$  tapped holes depending on the version.

The exhaust air connections must be protected against water and dust by using filters or other suitable measures.

**Note:** The  $K_{vs}$  value of a pressure reducer connected upstream must be at least 1.6 times larger than the  $K_{vs}$  value of the device.

### Supply pipe

The minimum required nominal size of the supply pipe is shown in the following table:

Nominal size (Supply pipe length $\leq$ 2 m)				
Press- ure  (bar)	$K_{vs}$ value			
		0.16 0.32	1.4	4.3
	Connection			
	4	1 and 3	4	9
$\geq 1.4$	$\geq$ DN 6	$\geq$ DN 8	$\geq$ DN 10	$\geq$ DN 4
$\geq 2.5$	$\geq$ DN 4	$\geq$ DN 6	$\geq$ DN 8	
$\geq 6$		$\geq$ DN 4	$\geq$ DN 6	

**Note:** Larger nominal sizes must be used for supply pipe lengths over 2 meters.

#### ► Type 3963-XXXXOX3/-XXXXO14

In the aboved listed devices, it is possible to check whether the nominal size of the supply pipe is sufficient as follows:

1. Unscrew the screw plug covering connection 9 and connect a pressure gauge.
2. The nominal size of the supply pipe proves to be sufficient when there is a pressure of  $\geq 1.3$  bar during the switching process.

## Operating medium for the booster valve

### With internal air supply:

Instrument air, free of corrosive particles, or nitrogen, pressure 1.4 to 6 bar.

### With external air supply via connection 9 (see page 7 ff.):

Instrument air, free of corrosive particles, oil-containing air or noncorrosive gases, pressure 0 to 6 bar (0 to 10 bar for  $K_{vs}$  value 1.4 or 4.3 with air supply via connection 4).

### Air supply for the pilot valve

Instrument air, free of corrosive particles, or nitrogen, pressure 1.4 to 6 bar.

### Quality of compressed air according to ISO 8573-1

Particle size and density	Oil contents	Pressure dew point
Class 4	Class 3	Class 3
$\leq 5 \mu\text{m}$ and $1\,000/\text{m}^3$	$\leq 1 \text{ mg}/\text{m}^3$	$-20^\circ\text{C}$ or at least 10 K below the lowest ambient temperature to be expected

### Note for using nitrogen:



When the devices are to be mounted in closed, unventilated rooms, the exhaust air of pilot valves or booster valves must be vented to the outside over a central pipe.

### Conversion to external air supply via connection 9

When the output signal (0 to 6 bar) of a positioner has to be switched by the solenoid valve, the air supply is to be connected external via connection 9.

#### ► Type 3963-XXXX004/-XXXX007/-XXXX014

In these devices, if not otherwise specified, the air supply is connected internally via connection 4. It can be converted to an external air supply via connection 9 (Fig. 9) as follows:

1. Unscrew the filister head screw and remove plate ① and gasket ② from the connecting plate.
2. Turn gasket ② by 90°. The **tab** of gasket ② is then placed **in cutout "9" of the connecting plate**.
3. Refasten plate ① and gasket ② to the connecting plate.

**Note:** In these devices, the flat gasket must be inserted as described for "Internal air supply via connection 4" (Fig. 11, page 8).

#### ► Type 3963-XXXX0X3/-XXXX006

In these devices, if not otherwise specified, the air supply is connected internally via connection 1 or 3. It can be converted to an external air supply via connection 9 (Fig. 10) as follows:

1. Unscrew the filister head screw and remove plate ① and gasket ② from the connecting plate.
2. Turn gasket ② by 180°. The **tab** of gasket ② is then placed **in cutout "9" of the connecting plate**.
3. Refasten plate ① and gasket ② to the connecting plate.

**Note:** In case of double actuated booster valves, this conversion must be performed in both pilot valves.

### Installation of the gasket for Type 3963-XXXX004/-XXXX007/-XXXX014

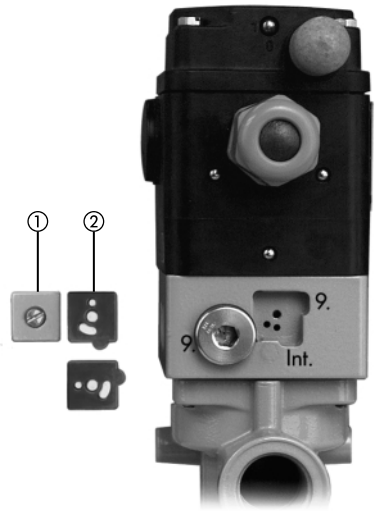

Fig. 9

### Installation of the gasket for Type 3963-XXXX0X3/-XXXX006

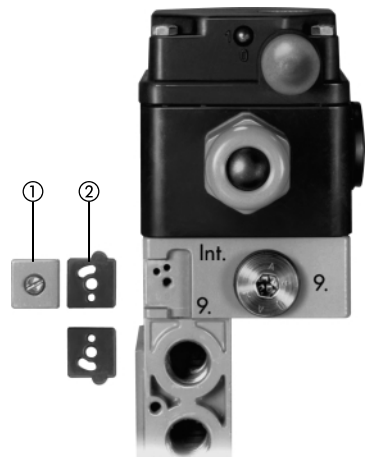

Fig. 10

- ▶ Type 3963-XXX0002/-XXX0012/  
-XXX0022/-XXX1011

In these devices, if not otherwise specified, the air supply is connected internally via connection 4. It can be converted to an external air supply via connection 9 (Fig. 11) as follows:

1. Unscrew the four filister head screws and remove enclosure cover.
2. Unscrew the three hexagon socket head screws and remove solenoid valve from the adapter plate.
3. Turn flat gasket by 180°. The **tab** of the flat gasket is then placed **in cutout "9"** of the enclosure.
4. Refasten solenoid valve and adapter plate.

- ▶ Type 3963-XXX0001/-XXX0011/  
-XXX0032/-XXX0101/  
-XXX0111/-XXX0131/  
-XXX1001/-XXX1201/  
-XXX8001

The air supply cannot be diverted in these devices. The flat gasket, if provided, must be inserted as described for "Internal air supply via connection 4" (Fig. 11).

### Exhaust air return

- ▶ Type 3963-XXX0013X

The connection 4 is sealed by a screw plug in the delivered state. If the exhaust air return is used for spring-loaded actuators, the screw plug must be removed and connection 4 must be connected to the spring chamber of the actuator by a hose with nominal size DN 4 to 10 (depending on the actuator size).

### Restrictors

- ▶ Type 3963-XXXX1/-XXXX2/-XXXX3

These devices have one or two restrictors. The restricting function can be identified from the symbol indicated on the device. Different closing and opening times can be adjusted in a ratio of 1:15 by turning the restricting screws clockwise or counterclockwise with a screwdriver. The restricting screws can be found underneath the enclosure cover or at the adapter plate (Fig. 12).

### Installation of the flat gasket for Type 3963-XXX0002/-XXX0012/ -XXX0022/-XXX1011

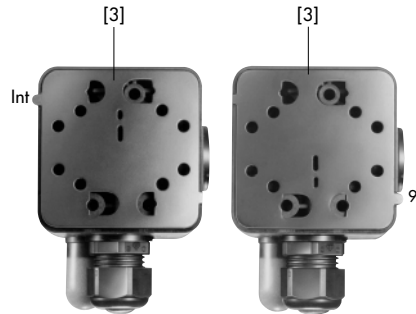

Internal air supply  
via connection 4

External air supply  
via connection 9

Fig. 11

### Setting of the restrictors

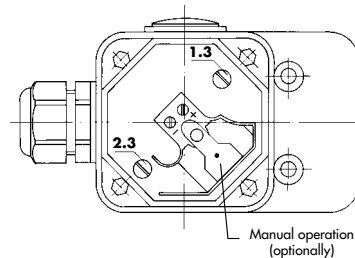

Type 3963-XXXX1/-XXXX2

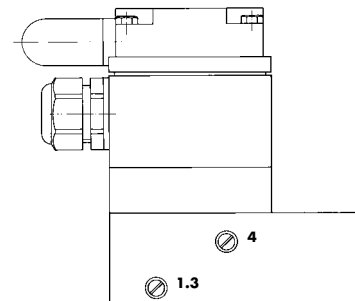

Type 3963-XXXX3

Fig. 12



## Electrical connection



As far as the electrical installation of the device is concerned, the relevant electrotechnical regulations and the accident prevention regulations of the country in which the device is used must be observed. In Germany these are the VDE regulations and the accident prevention regulations of the employers' liability insurance association.

For installation in hazardous areas, the respective national regulations of the country in which the device is used applies. In Germany these are VDE 0165/EN 60079.

For connection to certified intrinsically safe electric circuits, the EC Type Examination Certificate PTB 01 ATEX 2085 for Zone 1 and Certificate of Conformity PTB 01 ATEX 2086 X for Zone 2 or 22 applies (see pages 10 to 11). On connecting DC voltage signals, observe the correct polarity.

**Do not tamper with painted screws in the enclosure.**

The power supply is connected either through a cable gland  $M 20 \times 1.5$  to the terminals in the enclosure or with a plug-type connector (Fig. 13).

### Cable

It is recommended that connecting cables with a conductor cross-section of  $0.5$  to  $2.5 \text{ mm}^2$  are used. Connecting cables with an external diameter of  $6$  to  $12 \text{ mm}$  are suitable for the cable gland  $M 20 \times 1.5$ .

### Degree of protection

The devices can be changed from degree of protection IP 54 to degree of protection IP 65 by exchanging the filter in the enclosure cover.

### Manual operation

The devices have a manual operation as an alternative to allow the device to be manually operated when a nominal signal is not available:

- Switch in the enclosure cover
- Push button in the enclosure cover
- Pushbutton underneath enclosure cover (see page 8, Fig. 12)

**Note:** For **safety circuits**, only devices **without manual operation** should be used.

## Connection diagrams

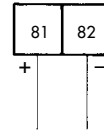

Terminals in the enclosure

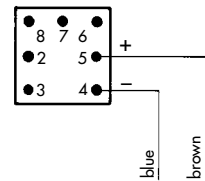

Female connector (manufactured by Harting)

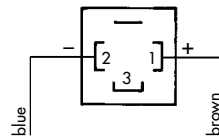

Female connector acc. to EN 175301-803

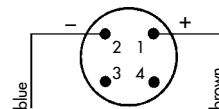

Female connector  $M 12 \times 1$

Fig. 13

# Approvals

EC Type Examination Certificate PTB 01 ATEX 2085 dated 08.08.2001 (extract)  
for Type 3963-1X Solenoid Valve (device index 13 or higher)



II 2 G EEx ia IIC T6

## for use in hazardous areas (Zone 1)

The correlation between version, temperature class, permissible ambient temperature and maximum permissible power dissipation is shown in the following table:

Type		3963-11	3963-12	3963-13
Nominal signal	$U_N$	6 V DC	12 V DC	24 V DC
Ambient temperature *)		-45 to +60 °C (temperature class T6) -45 to +70 °C (temperature class T5) -45 to +80 °C (temperature class T4)		
Power dissipation	$P_i$	250 mW	No limitation	
Internal inductance	$L_i$	Negligible		
Internal capacitance	$C_i$	Negligible		

\*) The minimum permissible ambient temperature is limited to -20 °C for Type 3963-1XXXXXXXXXX0 due to the materials of the filter and the electrical connection used

For connection to a certified intrinsically safe circuit the permissible maximum values are shown in the following table:

Voltage	$U_i$	25 V	27 V	28 V	30 V	32 V
Current	$I_i$	150 mA	125 mA	115 mA	100 mA	90 mA

**Note:** The EC Type Examination Certificate is available on request.

For use in hazardous areas (Zone 21) a manufacturer's declaration is available on request.

## Model number and device index

The model number and the device index are shown on the nameplate:

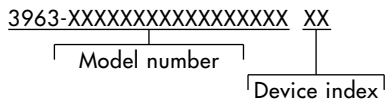

**Statement of Conformity PTB 01 ATEX 2086 X dated 14.11.2001 (extract)  
for Type 3963-8X Solenoid Valve (device index 13 and higher)**



**II 3 G EEx nA II T6**

**for use in hazardous areas (Zone 2 or 22)**

The correlation between version, temperature class and permissible ambient temperature is shown in the following table:

Type	3963-81	3963-82	3963-83
Nominal signal $U_N$	6 V DC	12 V DC	24 V DC
Ambient temperature *)	-45 to +60 °C (temperature class T6) -45 to +70 °C (temperature class T5) -45 to +80 °C (temperature class T4)		

\*) The minimum permissible ambient temperature is limited to  $-20\text{ °C}$  for Type 3963-8XXXXXXXXXX0 due to the materials of the filter and the electrical connection used

**Special conditions**

The required degree of protection IP 54 according to IEC 60529:1989 is only guaranteed with correct installation of the enclosure cover and electrical connection.

The wiring shall be connected in such a manner that the connecting cables are not subjected to tensile and torsional load.

**Model number and device index**

The model number and the device index are shown on the nameplate:

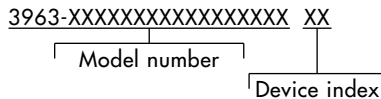

**Installation directions for devices certified by CSA for use in hazardous locations**

The devices may be installed in intrinsically safe circuits only when used in conjunction with the CSA certified devices (see Fig. 14).

The permissible maximum values of  $U_i$  or  $V_{max}$ ,  $I_i$  or  $I_{max}$ ,  $P_i$  or  $P_{max}$ ,  $C_i$  and  $L_i$  for the intrinsically safe circuit are shown in the following table:

<b>Solenoid valve</b>					
<b>Type</b>	<b><math>U_i</math> or <math>V_{max}</math></b>	<b><math>I_i</math> or <math>I_{max}</math></b>	<b><math>P_i</math> or <math>P_{max}</math></b>	<b><math>C_i</math></b>	<b><math>L_i</math></b>
<b>3963-11</b> ( 6 V DC)	$\leq 28$ V	$\geq 784$ mA	250 mW	0 nF	0 $\mu$ H
<b>3963-12</b> (12 V DC)	$\leq 28$ V	$\geq 240$ mA	No limitation	0 nF	0 $\mu$ H
<b>3963-13</b> (24 V DC)	$\leq 28$ V	$\geq 240$ mA	No limitation	0 nF	0 $\mu$ H

Note:  $U_0$  or  $V_{0C} \leq U_i$  or  $V_{max} / I_0$  or  $I_{max} \leq I_i$  or  $I_{max} / P_0 \leq P_i$  or  $P_{max} / C_0 \geq C_i / L_0 \geq L_i$

For barrier selection see the following table. In case of doubt as regards barrier selection, contact the manufacturer.

<b>Solenoid valve</b>	<b>Supply barrier</b>		<b>Evaluation barrier</b>	
	<b><math>V_{max}</math></b>	<b><math>R_{min}</math></b>	<b><math>V_{max}</math></b>	
<b>3963-11</b> ( 6 V DC)	$\leq 28$ V	$\geq 280$ $\Omega$	28 V	Diode return
<b>3963-12</b> (12 V DC)	$\leq 28$ V	$\geq 280$ $\Omega$	$\leq 28$ V	Diode return
<b>3963-13</b> (24 V DC)	$\leq 28$ V	$\geq 280$ $\Omega$	$\leq 28$ V	Diode return

The correlation between temperature class and permissible ambient temperature is shown in the following table:

<b>Temperature class</b>	<b>Permissible ambient temperature</b>
T 6	-45 to +60 °C
T 5	-45 to +70 °C
T 4	-45 to +80 °C

Installation shall be in accordance with the Canadian Electrical Code Part.

Use only supply wires suitable for 5 °C above ambient temperature.

## Connection diagrams

### CSA certified for hazardous locations:

Ex ia IIC;  
Class I, Zone 0  
Class I; Groups A, B, C, D  
Class II; Groups E, F, G;  
Class III

### Type 4 enclosure

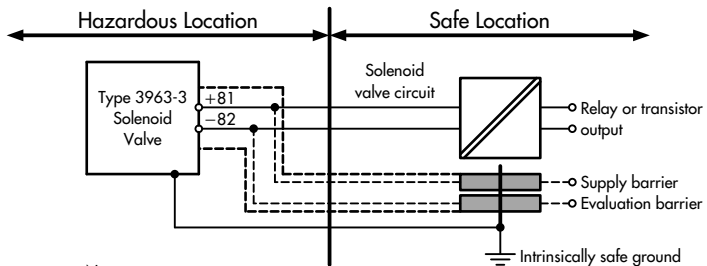

Note:  
Cable entry only rigid  
metal conduit according to  
drawings 1050-0539 T  
and 1050-0540 T

### CSA certified for hazardous locations:

Class I; Division 2, Groups A, B, C, D  
Class II; Division 2, Groups E, F, G;  
Class III

### Type 4 enclosure

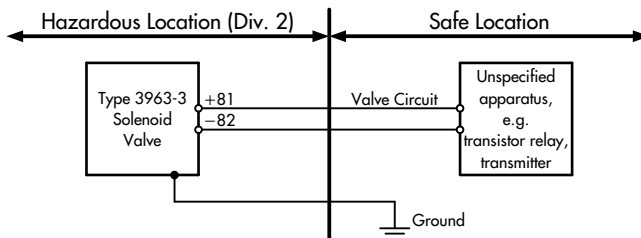

Note:  
Cable entry only rigid  
metal conduit according to  
drawings 1050-0539 T  
and 1050-0540 T

Fig. 14

## Addendum to EB 3963 EN (Revisions Control Number: 1 August 2004)

### Installation directions for devices certified by FM for use in hazardous locations

The devices may be installed in intrinsically safe circuits only when used in conjunction with the FM certified devices (see Fig. 15).

The permissible maximum values of  $U_i$  or  $V_{max}$ ,  $I_i$  or  $I_{max}$ ,  $P_i$  or  $P_{max}$ ,  $C_i$  and  $L_i$  for the intrinsically safe circuit are shown in the following table:

Solenoid valve					
Type	$U_i$ or $V_{max}$	$I_i$ or $I_{max}$	$P_i$ or $P_{max}$	$C_i$	$L_i$
<b>3963-11</b> ( 6 V DC)	$\leq 28$ V	$\geq 784$ mA	250 mW	0 nF	0 $\mu$ H
<b>3963-12</b> (12 V DC)	$\leq 28$ V	$\geq 240$ mA	No limitation	0 nF	0 $\mu$ H
<b>3963-13</b> (24 V DC)	$\leq 28$ V	$\geq 240$ mA	No limitation	0 nF	0 $\mu$ H

Note:  $U_0$  or  $V_{0C} \leq U_i$  or  $V_{max} / I_0$  or  $I_{max} \leq I_i$  or  $I_{max} / P_0 \leq P_i$  or  $P_{max} / C_0 \geq C_i / L_0 \geq L_i$

The devices may be installed in intrinsically safe circuits only when used in conjunction with the FM approved safe barrier. In case of doubt as regards barrier selection, contact the manufacturer. For the permissible barrier parameters for the circuit see the following table:

Solenoid valve	Supply barrier			Evaluation barrier		
	$V_{0C}$	$R_{min}$	$I_{0C}$	$V_{0C}$	$R_{min}$	$I_{0C}$
<b>3963-11</b> ( 6 V DC)	$\leq 28$ V	$\geq 784$ $\Omega$	$\leq 115$ mA	28 V	#	0 mA
<b>3963-12</b> (12 V DC)	$\leq 28$ V	$\geq 240$ $\Omega$	$\leq 115$ mA	$\leq 28$ V	#	0 mA
<b>3963-13</b> (24 V DC)	$\leq 28$ V	$\geq 240$ $\Omega$	$\leq 115$ mA	$\leq 28$ V	#	0 mA

The correlation between temperature class and permissible ambient temperature is shown in the following table:

Temperature class	Permissible ambient temperature
T 6	-45 to +60°C
T 5	-45 to +70°C
T 4	-45 to +80°C

Installation shall be in accordance with the National Electrical Code ANSI/NFPA 70 and ANSI/ISA RP 12.06.01.

Use only supply wires suitable for 5°C above ambient temperature.

## Connection diagrams

FM approved for hazardous locations:

A Ex ia IIC T6;

Class I, II, III, Division 1, Groups A, B, C, D, E, F, G

NEMA 4X

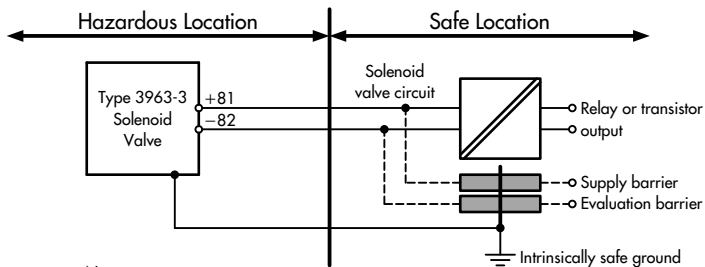

Note:  
Cable entry only rigid  
metal conduit according to  
drawings 1050-0539 T  
and 1050-0540 T

FM approved for hazardous locations:

Class I; Division 2, Groups A, B, C, D

Class I, Class II; Division 2, Groups F, G

Class III

NEMA 4X

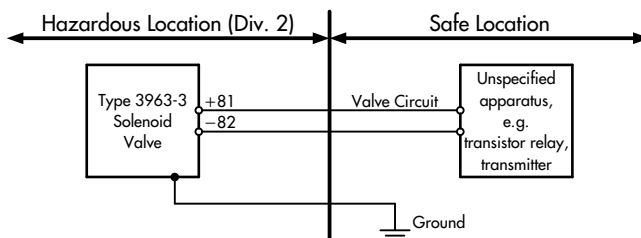

Note:  
Cable entry only rigid  
metal conduit according to  
drawings 1050-0539 T  
and 1050-0540 T

Fig. 15

Specifications subject to change without notice.

---

**SAMSOMATIC GMBH**

A member of the SAMSON GROUP

Weismüllerstraße 20-22  
60314 Frankfurt am Main · Germany  
Phone: +49 69 4009-0  
Fax: +49 69 4009-1644  
E-mail: [samsomatic@samson.de](mailto:samsomatic@samson.de)  
Internet: <http://www.samsomatic.de>

2009-03 · EB 3963 EN